

---

# **VISTA SERIES**

---

**2-PARTITIONED SECURITY SYSTEM**

## **4111XM INSTALLATION INSTRUCTIONS**

**Can Support 6 EOLR Wired Zones  
and**

(when used with appropriate wireless receiver and/or wired expansion unit)

**Up to a Total of 22 Expansion Zones**

(Including up to: 22 Wireless, and/or 8 Additional Wired)

**and**

(when used with appropriate output relay unit)

**2 or 4 Output Relays**



# **CONGRATULATIONS!**

## **On Your Purchase of the Ademco 4111XM**

The purpose of these Installation Instructions is to give you a complete overview of the system, and provide instructions for installing a basic system.

### **CONTACTING TECHNICAL SUPPORT**

**PLEASE,**

**Before you call Technical Support, be sure you:**

- **READ THE INSTRUCTIONS!**
- **Check all wiring connections.**
- **Determine that the power supply and/or backup battery are supplying proper voltages.**
- **Verify your programming information where applicable.**
- **Note the proper model number of this product, and the version level (if known) along with any documentation that came with the product.**
- **Note your ADEMCO customer number and/or company name.**

**Having this information handy will make it easier for us to serve you quickly and effectively.**

You may contact Technical Support via Toll Free Fax. Please include your return fax number. You will receive a reply within 24 hours. You may also contact Technical Support via modem to ATLIS-BBS, Tech Support's Electronic Bulletin Board System. Replies are posted within 24 hours.

*East Coast Technical Support: 1-800-645-7492 (8 a.m.-6 p.m. E.S.T.)*

*West Coast Technical Support: 1-800-458-9469 (8 a.m.-5 p.m. P.S.T.)*

*Technical Support Fax Number: 1-800-447-5086*

*ATLIS-BBS Electronic Bulletin Board System: 1-516-496-3980  
(1200 - 9600 Baud, 8 Data Bits, 1 Start/Stop Bit, No Parity)*

|  |
|--|
| <p><b>FOR YOUR CONVENIENCE,</b><br/>an easily removable Programming Form<br/>has been included at the center of this manual.</p> |
|--|

This system is not California State Fire Marshall approved and, as such, should not be used for fire protection in California (or other areas requiring such acceptance).

# TABLE OF CONTENTS

|  |   |
|--|---|
| <p><b>Section 1. GENERAL INFORMATION..... 4</b></p> <p style="padding-left: 20px;">Introduction .....4</p> <p style="padding-left: 20px;">Zone Characteristics.....5</p> <p><b>Section 2. SYSTEM CONFIGURATIONS..... 6</b></p> <p style="padding-left: 20px;">ZONE RESPONSE TYPE DEFINITIONS.....6</p> <p style="padding-left: 20px;">HARD WIRED ZONES.....7</p> <p style="padding-left: 40px;">Basic Control's Zones .....7</p> <p style="padding-left: 20px;">WIRED ZONE EXPANSION .....8</p> <p style="padding-left: 40px;">Nos. 4219 and 4229 Expansion Units .....8</p> <p style="padding-left: 20px;">WIRELESS EXPANSION, —5700 RF SYSTEM—.....9</p> <p style="padding-left: 40px;">General.....9</p> <p style="padding-left: 40px;">Supervision.....9</p> <p style="padding-left: 40px;">House Identification.....9</p> <p style="padding-left: 40px;">Transmitter Identification.....9</p> <p style="padding-left: 20px;">WIRELESS EXPANSION, —5800 RF SYSTEM—.....10</p> <p style="padding-left: 40px;">General.....10</p> <p style="padding-left: 40px;">Supervision.....10</p> <p style="padding-left: 40px;">House Identification.....10</p> <p style="padding-left: 40px;">Transmitter Identification.....10</p> <p style="padding-left: 40px;">Transmitter System Installation Options .....11</p> <p style="padding-left: 20px;">RELAY OUTPUTS.....12</p> <p style="padding-left: 40px;">Nos. 4204 and 4229 Output Relay Modules.....12</p> <p style="padding-left: 40px;">4204 Setup .....12</p> <p style="padding-left: 40px;">4229 Setup .....12</p> <p style="padding-left: 40px;">Relay Basics.....13</p> <p><b>Section 3. MOUNTING THE CONTROL, LOCK, &amp; PC BOARD ..... 14</b></p> <p style="padding-left: 20px;">Mounting the Cabinet .....14</p> <p style="padding-left: 20px;">Installing the Lock (if Used).....14</p> <p style="padding-left: 20px;">Installing the Control's Circuit Board Alone, or (if used), with a 4219, 4229, or 4204.....14</p> <p style="padding-left: 20px;">Installing Control and RF Receiver Circuit Boards Together, in the Same Cabinet .....15</p> <p><b>Section 4. WIRING &amp; POWERING THE SYSTEM.....16</b></p> <p style="padding-left: 20px;">Grounding the System.....16</p> <p style="padding-left: 20px;">Terminals and Connections .....16</p> <p style="padding-left: 20px;">Power-up Procedure .....17</p> <p><b>Section 5. SYSTEM OPERATION.....18</b></p> <p style="padding-left: 20px;">SECURITY CODES .....18</p> <p style="padding-left: 40px;">Installer Code.....18</p> <p style="padding-left: 40px;">Master Code.....18</p> <p style="padding-left: 40px;">Secondary User Codes.....18</p> <p style="padding-left: 20px;">KEYPAD FUNCTIONS .....18</p> <p style="padding-left: 40px;">General Information.....18</p> | <p style="padding-left: 20px;">Arming Functions ..... 19</p> <p style="padding-left: 20px;">Panic Keys ..... 19</p> <p><b>TROUBLE CONDITIONS..... 20</b></p> <p style="padding-left: 20px;">General Information.....20</p> <p style="padding-left: 20px;">"Check" and "Battery" Displays .....20</p> <p style="padding-left: 20px;">Power Failure.....20</p> <p style="padding-left: 20px;">Other Displays (Fixed Word Consoles).....20</p> <p><b>Section 6. PROGRAMMING THE SYSTEM..... 21</b></p> <p style="padding-left: 20px;">General Information .....21</p> <p style="padding-left: 20px;">Summary of Programming Commands.....22</p> <p style="padding-left: 20px;">Special Messages.....22</p> <p><b>PROGRAMMING DATA FIELDS.....23</b></p> <p><b>ALPHA DESCRIPTION ENTRIES.....30</b></p> <p style="padding-left: 20px;">Assigning Zone Descriptors.....30</p> <p style="padding-left: 20px;">Entering Zone Descriptors.....30</p> <p style="padding-left: 20px;">Adding Custom Words.....31</p> <p><b>ALPHA FIXED DICTIONARY (For Entering Zone Descriptors).....32</b></p> <p><b>CHARACTER (ASCII) CHART.....32</b></p> <p><b>Section 7. SYSTEM COMMUNICATION..... 33</b></p> <p style="padding-left: 20px;">Report Code Formats .....33</p> <p><b>Section 8. REMOTE PROGRAMMING AND CONTROL (DOWNLOADING)..... 34</b></p> <p style="padding-left: 20px;">General Information.....34</p> <p style="padding-left: 20px;">Equipment Required.....34</p> <p style="padding-left: 20px;">Programming.....34</p> <p style="padding-left: 20px;">Remote Programming Advisory Notes.....34</p> <p><b>Section 9. TESTING THE SYSTEM..... 36</b></p> <p style="padding-left: 20px;">Procedure.....36</p> <p><b>Section 10. SPECIFICATIONS &amp; ACCESSORIES ..... 39</b></p> <p style="padding-left: 20px;">SPECIFICATIONS.....39</p> <p style="padding-left: 20px;">ACCESSORIES (COMPATIBLE DEVICES).....41</p> <p><b>FCC STATEMENTS.....48</b></p> <p><b>CANADIAN DOC STATEMENT .....49</b></p> <p><b>LIMITATIONS OF THIS ALARM SYSTEM .....50</b></p> <p><b>LIMITED WARRANTY .....51</b></p> <p style="text-align: center; padding: 10px 0;"><u>Diagrams and Tables</u></p> <p><b>TROUBLESHOOTING GUIDE..... 37</b></p> <p><b>OUTPUT RELAY EXAMPLES TABLE..... 44</b></p> <p><b>DIP SWITCH TABLES FOR WIRELESS DEVICES..... 46</b></p> <p><b>SUMMARY OF CONNECTIONS DIAGRAM..... 47</b></p> <p><b>PROGRAMMING FORM.....Centerfold</b></p> |
|--|---|

# Section 1. GENERAL INFORMATION

## Introduction

|                 |   |
|-----------------|---|
| System          | The 4111XM is a microprocessor-based state-of-the-art 2-partitioned security control intended for wireless applications. This <i>partitioned</i> control provides an economical means of supplying <i>two</i> separate users with individual security systems, functioning as if each system had its own separate control. For example, the owner of a two family house can have an alarm system for his family (living upstairs) and also one for the separate living quarters of another (e.g., a tenant living downstairs, with a separate entrance).  |
| Zones Supported | Supports up to 28 zones, in the following configuration: <ul style="list-style-type: none"> <li>• 6 hard wired EOLR "basic" zones.</li> <li>• Up to 22 expansion zones (wireless and/or additional wired zones) by using an appropriate RF receiver( 4281 or 5881 type) or wired expansion unit (No. 4219 or 4229). Refer to the Zone Characteristics tabulation on the next page for detailed zone information.</li> </ul> <p><b>Note:</b> The <i>single</i> 4281/5881 type RF receiver that the 4111XM accommodates, features Spatial Diversity (dual antennas), which virtually eliminates the possibility of "Nulls" and "Dead Spots" within the coverage area.</p>   |
| Relay Outputs   | 2 or 4 output relays can be added, to perform programmable actions in response to zone activity or manual entries, by using a No. 4229 Wired Expansion/Relay Unit (8 wired zones and 2 output relays) or No. 4204 Relay Unit (4 output relays).   |
| Programming     | <p><b>A No. 5137 or 6139 Alpha Console connected to Partition 1 is required for programming both partitions' zones and relay operation, but it need not remain in the system.</b> These consoles have digital keypads and 2-line 32 character alphanumeric LCDs (Liquid Crystal Displays).</p> <p>Programmed options to establish specific alarm and reporting features are stored in electrically erasable, non-volatile EEROM memory. This means that the unit can be reprogrammed many times (unlike units with PROMs) and that information which has been programmed will not be lost in the event of a complete loss of power.</p> <p><b>The system's zones and relay outputs can be apportioned as desired between the control's two partitions or assigned to respond to both partitions.</b></p> <p>In addition, the system can be uploaded, downloaded, or controlled via a computer and Hayes modem (see <i>REMOTE PROGRAMMING AND CONTROL</i> on page 34).</p> |
| Remote Consoles | <p>After programming, either partition may use one or more 4127, 4137, 5137, 6127 or 6139 Consoles. The 4127, 4137, and 6127 have digital keypads and fixed English status LCDs.</p> <p><b>Note:</b> 4137AD and 5137AD (Addressable) Consoles may be used, provided they are set to their non-addressable mode (device ID 31...all DIP switch positions UP).</p> <p>With wireless in use, the system may also be armed and disarmed with a wireless keypad (No. 5727/5827) or other 5800 RF system units (e.g., Nos. 5801, 5802, 5803).</p>   |

### Alarm Output Advisory

This system includes an alarm output rated at 2 amps. Throughout the manual, wherever reference is made to Alarm Output Ratings, they assume a fully charged battery is connected, unless the UL rating is stated. The battery is periodically tested automatically (approximately every four hours), and if it cannot sustain a load, a low battery message is displayed and can be reported to the central station.

### Multiple Consoles

may be used in either partition, as long as their total current drain is within the alarm and auxiliary power output limitations described in the *SPECIFICATIONS AND ACCESSORIES* section.

**Zone Characteristics**

| User Codes  | In addition to the Installer code and the 2 partitions' Master codes, up to 2 secondary user codes can be assigned to each partition by the partition's Master code.  |              |                        |       |         |             |         |       |          |             |          |
|---|---|--------------|------------------------|-------|---------|-------------|---------|-------|----------|-------------|----------|
| Communication   | The system provides communication capability (central station reporting, etc.) over existing telephone lines.   |              |                        |       |         |             |         |       |          |             |          |
| <b>Zones 1-6</b><br>For more information, see page 7.                           | <b>Wired Programmable Zones.</b> EOLR supervised, N.O. or N.C. sensors, 300-500 msec normal response. <ul style="list-style-type: none"> <li>• Zone 3 is optionally fast (10-15msec) programmable.</li> <li>• Zone 5 is the one zone of these 6 that can be programmed as a fire zone (or other response type).</li> <li>• Zones are assignable individually to either partition.</li> </ul>  |              |                        |       |         |             |         |       |          |             |          |
| <b>Zones 7, 95, 96</b>  | <b>Console Panics</b> (Wired & Wireless). 24hr zones, programmable for silent, audible, auxiliary, or fire. Reported separately by partition.   |              |                        |       |         |             |         |       |          |             |          |
| <b>Zone 8</b>   | <b>Duress</b> (see User's Manual).  |              |                        |       |         |             |         |       |          |             |          |
| <b>Zone 9</b>   | <b>Tamper.</b> Reports with appropriate Partition 1 and/or 2 Subscriber No.: Faults in the expansion units (e.g., 4219, 4229, 4281), tampers on 5800 System RF units (5881), and trouble-by-day/alarm-by-night zones. For all report formats (except Contact ID, which provides more explicit reporting) a trouble code is reported when the system is not armed, and Zone 9 report code is sent for an alarm.  |              |                        |       |         |             |         |       |          |             |          |
| <b>Additional Wired Programmable Zones</b><br>For more information, see page 8. | <b>Up to 8 loops can be added</b> , with a 4219 Wired Expansion Unit or No. 4229 Wired Expansion/Relay Unit. Loops are EOLR supervised, for N.O. or N.C. sensors, 300-500 msec normal response, with optional fast (10-15 msec) response on loop A (first expansion zone). Zone numbers <b>10-17</b> should be assigned (individually to either partition) when using a 4219 or 4229 for zone expansion.  |              |                        |       |         |             |         |       |          |             |          |
| <b>Wireless Zones</b><br>For more information, see pages 9-11.                  | <b>Up to 22 wireless (RF) zones can be added</b> by using an Ademco 4281(5700 System) or 5881 (5800 System) Type RF Receiver. Specifically: <table border="1" style="margin-left: auto; margin-right: auto;"> <thead> <tr> <th><u>Model</u></th> <th><u>Number of Zones</u></th> </tr> </thead> <tbody> <tr> <td>4281L</td> <td>Up to 4</td> </tr> <tr> <td>4281M/5881L</td> <td>Up to 8</td> </tr> <tr> <td>5881M</td> <td>Up to 16</td> </tr> <tr> <td>4281H/5881H</td> <td>Up to 22</td> </tr> </tbody> </table> <p>Zone number assignments (which are also transmitter ID assignments for 5700 RF system transmitters) can be in the <b>10-63</b> range (<b>18-63</b> when a 4219 or 4229 is also used). A variety of RF system transmitters can be used to make up the wireless zones. This includes window/door units, smoke detectors, PIRs, and panic keys. Each zone is assignable to either partition.</p> <p><b>Note:</b>For brevity, subsequent references herein to the RF Receiver will be indicated by "4281/5881" unless a specific model is named.</p> | <u>Model</u> | <u>Number of Zones</u> | 4281L | Up to 4 | 4281M/5881L | Up to 8 | 5881M | Up to 16 | 4281H/5881H | Up to 22 |
| <u>Model</u>  | <u>Number of Zones</u>  |              |                        |       |         |             |         |       |          |             |          |
| 4281L   | Up to 4   |              |                        |       |         |             |         |       |          |             |          |
| 4281M/5881L   | Up to 8   |              |                        |       |         |             |         |       |          |             |          |
| 5881M   | Up to 16  |              |                        |       |         |             |         |       |          |             |          |
| 4281H/5881H   | Up to 22  |              |                        |       |         |             |         |       |          |             |          |

**If (4219/4229) wired expansion zones and (4281/5881) wireless expansion zones are to be added, they can comprise up to 8 (4219/4229) wired zones, plus wireless zones up to the number permitted by the type of 4281/5881 RF receiver used, as long as the total does not exceed the 22 expansion zones accommodated by the control.**

**For example:** When all 8 loops of a 4219 or 4229 are to be used, a 4281H or 5881H can add only 14 zones, so as not to exceed a total of 22 expansion zones for this control.

## Section 2. SYSTEM CONFIGURATIONS

### ZONE RESPONSE TYPE DEFINITIONS

#### General Information

Each zone must be assigned to a zone type, which defines the way in which the system responds to faults in that zone. Zone types are defined below ("*Type 02*" is not used in this system).

#### Type 00

##### Zone Not Used

Program a zone with this zone type if the zone is not used.

#### Type 01

##### Entry/Exit Burglary

This zone type provides entry delay whenever the zone is faulted if the control is armed in the Away or Stay modes. When the panel is armed in the Instant or Maximum modes, no entry delay is provided. Exit delay begins whenever the control is armed, regardless of the arming mode selected. These delays are programmable. This zone type is usually assigned to sensors or contacts on doors through which primary entry and exit will take place.

#### Type 03

##### Perimeter Burglary

This zone type gives an instant alarm if the zone is faulted when the panel is armed in the Away, Stay, Instant or Maximum modes. This zone type is usually assigned to all sensors or contacts on exterior doors and windows.

#### Type 04

##### Interior, Follower

This zone type gives a delayed alarm (using the programmed Entry/Exit time) if the Entry/Exit zone is faulted first. Otherwise this zone type gives an instant alarm. This zone type is active when the panel is armed in the Away and Maximum modes. **This zone type is bypassed automatically when the panel is armed in the Stay or Instant modes.** This zone type is usually assigned to a zone covering an area such as a foyer, lobby, or hallway through which one must pass upon entry (After faulting the entry/exit zone to reach the console to disarm the system.) Since this zone type is designed to provide an instant alarm if the entry/exit zone is not violated first, it will protect an area in the event an intruder hides on the premises prior to the system being armed, or gains access to the premises through an unprotected area.

#### Type 05

##### Trouble by Day/ Alarm by Night

This zone type will give an instant alarm if faulted when armed in the Away, Stay, Instant or Maximum (night) modes. During the disarmed state (day), the system will provide a latched trouble sounding from the console (and a central station report, if desired). This zone type is usually assigned to a zone which contains a foil-protected door or window (such as in a store), or to a zone covering a "sensitive" area such as a stock room, drug supply room, etc. This zone type can also be used on a sensor or contact in an area where immediate notification of an entry is desired.

#### Type 06

##### 24-hour Silent Alarm

This zone type sends a report to the Central Station but provides no console display or sounding. This zone type is usually assigned to a zone containing an Emergency button.

#### Type 07

##### 24-hour Audible Alarm

This zone type sends a report to the Central Station, and provides a rapid beeping sound at the console, and an audible external alarm. This zone type is usually assigned to a zone that has an Emergency button.

#### Type 08

##### 24-hour Auxiliary Alarm

This zone type sends a report to Central Station and provides a rapid beeping sound at the console. **(No bell output is provided).** This zone type is usually assigned to a zone containing a button for use in personal emergencies, or to a zone containing monitoring devices such as water or temperature sensors, etc.

#### Type 09

##### Supervised Fire

This zone type provides a fire alarm on short circuit and a trouble condition on open circuit. The bell output will pulse when this zone type is faulted. This zone type is always active and cannot be bypassed. **This zone type can be assigned to control panel wired zone 5, any zone in a wired zone expansion module, or certain wireless zones.**

#### Type 10

##### Interior w/Delay

This zone type gives *entry* delay (using the programmed entry time), if tripped when the panel is armed in the Away mode. Entry delay begins whenever sensors in this zone are violated, regardless of whether or not an entry/exit delay zone was tripped first. *No entry delay* is provided if tripped when the panel is armed in the Maximum mode. *Exit* delay is present for *any* arming mode. **This zone type is bypassed when the panel is armed in the Stay or Instant modes.**

- Type 20**  
**Arm-Stay** This is a special purpose zone type used with 5800 series wireless pushbutton or contact closure or opening, and which will result in arming the system in the STAY mode when the zone is activated.
- Type 21**  
**Arm-Away** This is a special purpose zone type used with 5800 series wireless pushbutton or contact closure or opening, and which will result in arming the system in the AWAY mode when the zone is activated.
- Type 22**  
**Disarm** This is a special purpose zone type used with 5800 series wireless pushbutton or contact closure or opening, and which will result in disarming the system when the zone is activated.
- Type 23**  
**No Alarm Response** This zone type can be used on a zone when an output relay action is desired, but with no accompanying alarm (ex. lobby door access).

By using a 4281/5881 RF Receiver and the appropriate 5700/5800 series transmitters, all of the above zone types are available for the wireless portion of the system.

## HARD-WIRED ZONES

**Basic Control's Zones** The 4111XM supports 6 hard-wired zones, which are connected as zones 1–6. These zones must be EOLR supervised, and can use N.O. and/or N.C. sensors. Zones are assignable individually to either partition.

|                             |  |
|-----------------------------|--|
| <b>Zone Response Type</b>   | Any zone response can be assigned to devices on these zones, except Supervised Fire (09), which can be assigned only to zone 5 (see below).  |
| <b>Response Time</b>        | 300–500 msec normal response. Optional fast (10–15 msec) response programmable for zone 3.   |
| <b>Max. Zone Resistance</b> | 300 ohms, excluding EOLR.  |
| <b>EOLR Supervised</b>      | <ul style="list-style-type: none"> <li>• Supports both open circuit and closed circuit devices.</li> <li>• Connect open circuit devices in parallel across the loop. The 1,000 ohm EOLR must be connected across the loop wires <b>at the last device</b>.</li> <li><b>Important:</b> If the EOLR is not at the end of the loop, the zone is not properly supervised. The system may not respond to an open circuit within the zone.</li> <li>• Connect closed circuit devices in series with the loop.</li> </ul> |
| <b>EOLR Fire Zone 5</b>     | <ul style="list-style-type: none"> <li>• Only zone 5 can be used for fire.</li> <li>• Supports as many 4-wire smoke detectors as can be powered.</li> <li>• The zones must be configured for EOLR supervision.</li> <li>• The detectors must be wired in parallel, with the EOLR at the last detector for full supervision.</li> <li>• To supervise power, a supervisory module (e.g., System Sensor A7771601 EOL Relay Module) is required.</li> </ul>  |

## WIRED ZONE EXPANSION

### Nos. 4219 and 4229 Expansion Units

If a No. 4219 Wired Expansion Unit, or 4229 Wired Expansion/Relay Unit is used, 8 wired EOLR zones can be added to the basic control's 6 zones, for a total of 14.

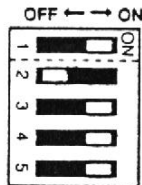

|                         |   |
|-------------------------|---|
| <b>Location</b>         | Can be mounted within or outside of the control's cabinet (see page 14).  |
| <b>Connections</b>      | Connects to the control's Partition 1 remote console terminals for signaling.   |
| <b>Supervision</b>      | <ul style="list-style-type: none"> <li>Supervised against removal.</li> <li>Has tamper protection for security when mounted outside of the cabinet.</li> </ul>  |
| <b>Zone Information</b> | <ul style="list-style-type: none"> <li>Eight wired expansion loops (designated A to H) should be assigned zone numbers 10-17, and any or all can be programmed individually (in field *56) for Partition 1 or 2.</li> <li>If RF will be used in addition to one of these units (see <i>WIRELESS EXPANSION</i> sections), any zone numbers in the range of 18-63 (<i>not</i> 10-17) should be chosen for the RF zones, <i>even if some of the unit's wired expansion loops are not being used.</i></li> </ul> <p><b>For example:</b></p> <p>If only four of the wired expansion loops are being used, a 4281H or 5881H RF Receiver could add 18 RF zones (using any zone numbers in the range of 18-63) to the system, for a combined total of 22 expansion zones.</p> <p>If a 4219 or 4229 is <i>not</i> being used, however, the same receiver could add 22 RF expansion zones to the system, assigned <i>any</i> zone numbers within a 10-63 range.</p> |
| <b>Settings</b>         | <p>The 4219's or 4229's DIP switch must be set for a device address of "1", as described in its instructions (bottom 3 switches to the RIGHT..."on", and the next switch above to the LEFT..."off"). Switch 1 determines zone A's response time ("ON" = normal response, "OFF" = fast response).</p>  |

For additional information, see the instructions that accompany the 4219 and 4229.



## WIRELESS EXPANSION

## — 5700 RF SYSTEM —

### General

In addition to its basic 2 wired zones, the control, in conjunction with a 4281RF Receiver, can provide wireless zones [4281L: up to 4 zones, 4281M: up to 8, 4281H (in this application): up to 22]. A wireless keypad (5727) also can be used with the system for Partition 1.

The receiver can be mounted within the control's cabinet (see page 15) or installed remotely, in its own housing.

The 4281 recognizes alarms, status messages and keypad control messages from 5700 Series Wireless Transmitters operating at 345Mhz (315Mhz for Canadian version). These messages are processed and relayed to the control panel via a 4 wire connection to the control's Partition 1 remote console terminals. The 4281's RED, BLACK, YELLOW, and GREEN wires are connected in parallel with console wiring.

The 4281 can receive signals from wireless transmitters (listed below) within a nominal range (installed) of 200 feet.

The 4281 can receive signals from wireless transmitters (listed below) within a nominal range (installed) of 200 feet.



**The 4281's DIP switch must be set for a device address of "0", as described in the 4281's instructions (all switches to the RIGHT... "off").**

### Supervision

Each transmitter (except 5701 and 5727) is supervised by a check-in signal that is sent to the receiver at 70-90 minute intervals. If at least one check-in is not received from each *supervised* transmitter within a 12 hour period, the "missing" transmitter number(s) and "CHECK" will be displayed on the console.

Each transmitter (including 5701) is also supervised for low battery conditions and will transmit a low battery signal to the 4281, with the battery having at least 30 days of life remaining. If the 5727 transmits and has a low battery, it also will be indicated (as Zone 00 on a fixed English console).

**Note:** After a low or dead battery is replaced, activate the transmitter and then enter the security code + OFF to clear the system's memory of the "Low Battery" signal.

The 4281 itself is supervised. *If communication with the receiver is interrupted, or valid RF signals from at least one supervised wireless transmitter are not received within 12 hours, a tamper report (Zone 9) will be generated.*

### House Identification

The 4281 responds only to transmitters set to the same House ID (01-31, see the DIP switch tables on page 46) as programmed in the control (see field \*24). This prevents interference from transmitters in other nearby systems. To make sure that a House ID is chosen that is not in use nearby, conduct the Sniffer Mode test described under *TESTING THE SYSTEM*.

### Transmitter Identification

#### 5700 RF System Installation Advisories

1. If the 4281 Receiver is to be mounted remotely (not in the control's cabinet), place it in a high, centrally located area for best reception.
2. Do not locate receiver or transmitters on or near metal objects. This will decrease range and/or block transmissions.
3. Before mounting transmitters permanently, conduct Go/No Go Tests to verify adequate signal strength (see *TESTING THE SYSTEM*) and reorient or relocate transmitters if necessary.

Each transmitter's assigned zone number is DIP switch programmable in the unit as its transmitter ID (except wireless keypads, which are fixed at ID 00). Whenever a transmission takes place, whether for an alarm, fault, check-in, or low battery, the ID number is sent along with the message to the 4281 which, in turn, relays this information to the control, which displays the condition and zone number on the console.

**WIRELESS TRANSMITTERS** for the 4281 are described on page 41.

**DIP SWITCH SETTING TABLES** are shown on page 46.

**Transmitters set for IDs of 48-55 (FIRE)** have high signal priority and will transmit once every 12 seconds while the zone is faulted.

**Transmitter IDs of 62 and 63** are unsupervised to allow removal of the 5701 off-premises. Signal priority is higher than burglary.

**Transmitters set for IDs of 56-63** will transmit once every 3 seconds while faulted.

**Transmitters set for IDs of 32-47** will have a 3 minute lock-out between transmissions to conserve battery life (normally PIR units).

**Note:** To conserve battery life, transmitters protecting *frequently used doors* and windows should be set for IDs in the 32-47 range.

## WIRELESS EXPANSION

## — 5800 RF SYSTEM —

### General

In addition to its basic 2 wired zones, the control, in conjunction with a 5881 RF Receiver, can provide wireless zones [5881L: up to 8 zones, 5881M: up to 16, 5881H (in this application): up to 30]. Wireless keypads (5827) also can be used with the system.

The receiver can be mounted within the control's cabinet (see page 15) or installed remotely, in its own housing.

The 5881 recognizes alarms, status messages and keypad control messages from 5800 Series Wireless Transmitters operating at 345Mhz. These messages are processed and relayed to the control panel via a 4 wire connection to the control's Partition 1 remote console terminals. The 5881's RED, BLACK, YELLOW, and GREEN wires are connected in parallel with console wiring.

The 5881 can receive signals from wireless transmitters (listed below) within a nominal range (installed) of 200 feet.

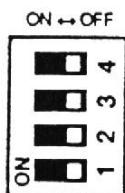

**The 5881's DIP switch must be set for a device address of "0", as described in the 5881's instructions (all switches to the RIGHT..."off").**

### Supervision

Each transmitter (except 5802, 5802CP, 5803, and 5827) is supervised by a check-in signal that is sent to the receiver at 70-90 minute intervals. If at least one check-in is not received from every *supervised* transmitter within 12 hours, the "missing" transmitter number(s) and "CHECK" will be displayed on the console. The supervision for a particular transmitter may be turned off by learning it as a "UR" (unsupervised RF) type.

Each transmitter is also supervised for low battery conditions and will transmit a low battery signal to the 5881, with the battery having at least 30 days of life remaining. If the 5802, 5802CP, 5803, or 5827 transmits and has a low battery, it will also be indicated.

**Note:** After a low or dead battery is replaced, activate the transmitter and then enter the security code + OFF to clear the system's memory of the "Low Battery" signal.

Some transmitters (e.g. 5802, 5802CP, and 5803) contain long-life but non-replaceable batteries. At the end of their life, the complete unit must be replaced [and new identification code(s) learned by the control...see *Transmitter Identification* below].

The 5881 itself is supervised. *If communication with the receiver is interrupted, or valid RF signals from at least one supervised wireless transmitter are not received within 12 hours, a tamper report (Zone 9) will be generated.*

### House Identification

If a 5827 Wireless Keypad is used with the system, it must have its DIP switch set to the same House ID (01-31) as programmed in the control for the RF receiver (see programming field \*24) to establish proper communication. *DIP switch setting information for the 5827 is given on page 46.*

### Transmitter Identification

Each transmitter *input* has a different ID (identification) code, part of which includes a unique serial number permanently assigned to the device during manufacture. Many transmitters have more than one input, hence ID code (e.g., 5801 has 4, 5803 has 3, etc.).

It is not necessary to assign a transmitter's ID(s) during installation. Instead, the control must learn or be programmed for each transmitter's ID code(s) during programming, in conjunction with assigned zone number(s) and other data. Whenever a transmission takes place, whether for an alarm, fault, check-in, or low battery, the ID code is sent as part of the message to the 5881. In turn, the information is relayed to the control, which displays the condition and associated zone number on the console.

**WIRELESS TRANSMITTERS for the 5881 are described on page 42.**

## Transmitter System Installation Options

To install the particular transmitters in the system, one of two optional methods can be used. Option 1, whose procedure is described in general below, and in detail in *PROGRAMMING THE SYSTEM* on page 21, involves having the system learn each transmitter to be used in the system. Option 2 (to be available soon), described below, involves the downloader, where the IDs can be entered manually at the office and then downloaded to an operating system.

### OPTION 1

#### *Learning and Assigning ID Codes at the Control*

Each transmitter sends its unique serial number with each transmission, but since some devices have more than one sensor point (input), and the sensor point is part of the ID, each ID must be learned and assigned separately.

As part of the programming of each zone, the device type is entered, and following that, the display of "Learn S/N?" comes up. If the control is to be taught the IDs now, pressing [1] will get the display "Transmit Now".

The control program is now at a zone number to be assigned to a given transmitter input (multi-point contact, single-point motion detector, single-point smoke detector, multi-point emergency transmitter, etc.). A transmitter will either be already installed, or one of a group of transmitters to be installed at a given site. The corresponding transmitter point (input) is then activated to generate a complete event transmission (e.g., opening and closing a contact, closing and opening a contact, pressing and releasing a button, causing alarm and restore, etc.). The resulting transmission will contain an ID code identifying the device by serial number and its activated point.

If the ID code of this first transmission event has not been previously learned, the assignment of zone number and ID code (device serial number and sensor point) is stored in the control memory. Concurrent with this first event, the console emits a single, short sound to acknowledge this fact and to request a duplicate transmission event to verify the assignment. Upon completion of a second identical transmission event (within a pre-determined time limit), the control compares this second (verify) event with the first (learn) event. If the two events match, the control keeps the assignment in EEPROM memory and the console emits a double, short acknowledge sound.

If the ID of the first transmission event was previously learned, a single, long error sound is emitted. If the second (verify) transmission event does not match the first (learn) transmission event, the ID of the first transmission event is erased and the assignment is discarded.

In this mode, the selected zone number for that transmitter sensor point together with other system attributes associated with that particular zone are concurrently assigned to the "learned" ID code.

### OPTION 2

#### *Manual ID Code Assignment Method*

(TO BE AVAILABLE SOON)

Supplements *REMOTE PROGRAMMING AND CONTROL (DOWNLOADING)* section on page 34.

At the downloader computer location, the downloader for the 4111XM is brought up.

The identification code numbers can be entered at the screens where the zone characteristics and communicator reporting codes are entered. If the 5800 RF system has been properly selected (RF expander type 5881) on a previous screen, the type of transmitter and identification code (which includes input loop data) can be entered on the same line as the other items for each zone. The factory pre-recorded serial number is read from the non-removable portion of the transmitter case in a 7-decimal digit (telephone number) format.

Mark the transmitters to be used in the installation (multi-point contact, single-point motion detector, single point smoke detector, multi-point emergency sensor, etc.) and enter their ID codes when programming other data for the system. When the data that defines the system is downloaded, the identification codes will be downloaded also and stored in EEPROM memory.

#### 5800 RF System Installation Advisories

1. If the 5881 Receiver is to be mounted remotely (not in the control's cabinet), place it in a high, centrally located area for best reception.
2. Do not locate receiver or transmitters on or near metal objects. This will decrease range and/or block transmissions.
3. Before mounting transmitters permanently, conduct Go/No Go Tests to verify adequate signal strength (see *TESTING THE SYSTEM*) and reorient or relocate transmitters if necessary.

## RELAY OUTPUTS

### Nos. 4204 and 4229 Output Relay Modules

The 4111XM can support relay outputs via the use of either a 4204 (4 outputs) or a 4229 (2 outputs). These modules provide form C (normally open and normally closed) dry contacts on relays that can be programmed, in conjunction with either or both partitions, to activate or deactivate to perform some action in response to a predetermined event, such as turning on lights and/or closing a fire door in the event of a fire alarm condition. There are many different uses for these relays, some of which are suggested in the table on page 44.

The unit can be located inside the control's cabinet or remotely (see *MOUNTING THE CONTROL, LOCK, & PC BOARD* section and the instructions that accompany the unit).

#### 4204 Setup

The 4204 Relay Unit has 4 Form C relays. Each relay can be used independently for different functions. The following steps should be taken to properly set up the 4204:



1. **Connect the 4204 to the control's Partition 1 remote console terminals (4-7)**, using standard 4-conductor twisted cable (for long wiring runs) or the connector supplied with the 4204 (as shown in the *Summary of Connections* diagram).

2. **Set the 4204's DIP switch for a device address of "1"** (switch 2 "OFF" and switches 3, 4, 5 "ON"). Switch 1 determines the unit's cover tamper response ("ON" = disabled, "OFF" = enabled).

**Note:** Some "early" units have only a 4-position DIP switch. Set 1 to "OFF" and 2, 3, 4 to "ON".

3. **During programming** (summarized here, but see the detailed procedure in the *PROGRAMMING THE SECURITY CONTROL* section):

a. Program a "3" in field \*25.

b. Program fields \*80 (Output Relays) and \*81 (Zone Lists) for the desired relay responses.

4. **Connect the desired field wiring** to the unit's relay contact terminals.

#### 4229 Setup

The 4229 Wired Expansion/Relay Unit has 8 hard-wired zones and 2 Form C relays. Each relay can be used independently for different functions. The following steps should be taken to properly set up the 4229:

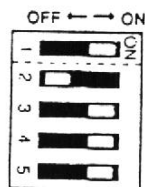

1. **Connect the 4229 to the control's Partition 1 remote console terminals (4-7)**, using standard 4-conductor twisted cable (for long wiring runs) or the connector supplied with the 4229 (as shown in the *Summary of Connections* diagram).

2. **Set the 4229's DIP switch for a device address of "1"** (switch 2 "OFF" and switches 3, 4, 5 "ON"). Switch 1 determines zone A's response time ("ON" = normal response, "OFF" = fast response).

3. **During programming** (summarized here, but see the detailed procedure in the *PROGRAMMING THE SECURITY CONTROL* section):

a. Program a "2" in field \*25.

b. Program fields \*80 (Output Relays) and \*81 (Zone Lists) for the desired relay responses.

c. In field \*56 (zone programming), assign zone numbers 10-17 to the 4229's wired expansion zones.

4. **Connect the desired field wiring** to the unit's relay contact terminals.

## Relay Basics

Relays can be used to perform many different functions and actions. In this system, each relay must be programmed as to how to act (ACTION), when to activate (START), and when to deactivate (STOP). Each of these is summarized briefly below, but described later in detail in the programming procedure for fields \*80 and \*81.

1. **ACTION:** The "ACTION" of the relay is how the relay will respond when it is activated by the "START" programming. There are 4 different choices of actions:
  - CLOSE for 2 SECONDS and then reset.
  - CLOSE and remain activated until deactivated by "STOP" programming.
  - PULSE ON and OFF until deactivated by "STOP" programming.
  - NO RESPONSE is chosen when the relay is not used.
2. **START:** The "START" programming instructs the relay when and under what conditions to activate. There are 4 parts to be programmed:
  - EVENT instructs the relay what condition must occur to the zone(s) programmed into the "ZONE LIST" in order to activate the relay. The "EVENT" and "ZONE LIST" work together. The 4 different choices for "EVENT" are listed in the PROGRAMMING section for field \*80.
  - ZONE LIST is a list of zones selected by the installer in field \*81. When an event occurs as assigned by "EVENT" on any zone within that list, the relay will activate as selected in "ACTION". In this way, many zones can be assigned very easily to a single event. **For example:** You may wish a relay to activate (perhaps to activate a strobe for a visual indication) whenever any zone in a group of zones is faulted.
  - ZONE TYPE/SYSTEM OPERATION. Instead of using a "ZONE LIST" and "EVENT", a specific zone (response) type or system operation action can be selected to activate the relay.
    - If a specific "ZONE TYPE" is chosen**, any zone of that response type going into alarm, trouble, or fault will cause the relay to activate as selected in "ACTION". Any zone of that type that restores will deactivate the relay.
    - If a "SYSTEM OPERATION" is chosen**, that operation will cause the relay to activate as selected in "ACTION".

The different choices for "ZONE TYPE" and "SYSTEM OPERATION" are listed in the PROGRAMMING section for field \*80.

  - PARTITION No. The relay's "Start" Zone Type/System Operation may be programmed to act in conjunction with Partition 1, Partition 2, or either.
3. **STOP:** The "STOP" programming instructs the relay when and under what conditions to deactivate. The 3 parts to be programmed are:
  - RESTORE ZONE LIST. If a "RESTORE ZONE LIST" is used, the relay will deactivate when all the zones in that list restore from a previous fault of alarm condition. This will occur regardless of what is programmed to "START" the relay; therefore, a "RESTORE ZONE LIST" would normally only be used when a "ZONE LIST" is used to start the relay.
  - ZONE TYPE/SYSTEM OPERATION. Instead of using a "RESTORE ZONE LIST", a specific zone (response) type or system operation action can be selected to deactivate the relay.
    - If a specific "ZONE TYPE" is chosen**, any zone of that response type that restores from a previous alarm, trouble, or fault condition will cause the relay to deactivate.
    - If a "SYSTEM OPERATION" is chosen**, that operation will cause the relay to deactivate.

The different choices for "ZONE TYPE" and "SYSTEM OPERATION" are listed in the PROGRAMMING section for field \*80.

  - PARTITION No. The relay's "Stop" Zone Type/System Operation may be programmed to act in conjunction with Partition 1, Partition 2, or either.

### Output Relay Advisory

*If a relay is energized before a wired smoke detector is reset, the relay will be stopped by the interruption of Aux. Power that resets the smoke detector. If this is not desired, the power to the relay unit should be supplied from another 12V power source (e.g., the same source that is powering external equipment through the relay contacts).*

# Section 3. MOUNTING THE CONTROL, LOCK, & PC BOARD

## Mounting the Cabinet

The 4111XM is supplied with a 12-1/2" (318mm) wide x 14-1/2" (368mm) high x 3" (76mm) deep cabinet suitable for use in residential installations.

Mount the control cabinet to a sturdy wall using fasteners or anchors (not supplied) in a clean, dry area which is not readily accessible to the general public. 4 mounting holes are provided at the back of the cabinet.

## Installing the Lock (if Used)

The cabinet can be closed and secured *without* a lock by using 2 screws in the cover's edge.

Use an Ademco No. N6277 Cam Lock and No. N6277-1 Push-On Clip (Retainer Clip).

1. Remove the cabinet cover. *It is easily removable for servicing and is easily reinstalled.*
2. Remove the lock knockout from the control cabinet cover. Insert the key into the lock. Position the lock in the hole making certain that the latch will make contact with the latch bracket when the door is closed.
3. While holding the lock steady, insert the retainer clip into the retainer slots. Position clip as illustrated to facilitate easy removal.

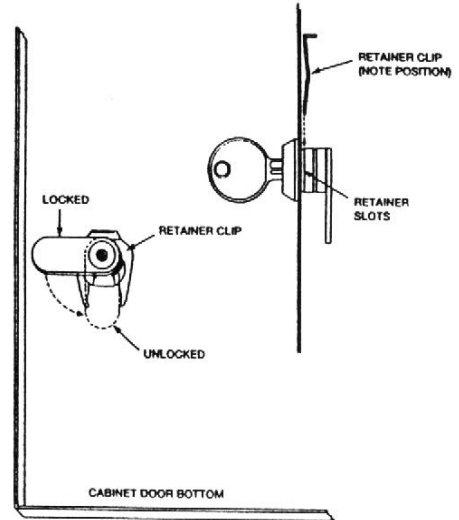

## Installing the Control's Circuit Board Alone, or (if used), with a 4219, 4229, or 4204

**IMPORTANT!**  
Before installing the cabinet's contents, be sure to remove the appropriate metal cabinet knockouts.  
DO NOT ATTEMPT TO REMOVE THE KNOCKOUTS AFTER THE CIRCUIT BOARD HAS BEEN INSTALLED.

## Control's Circuit Board

1. Hang two *long* mounting clips (provided) on the raised cabinet tabs (see Detail B below).
2. Insert the top of the circuit board into the slots at the top of the cabinet. Make sure that the board rests on the correct row (see Detail A).
3. Swing the base of the board into the mounting clips and secure the board to the cabinet with the accompanying screws (see Detail B).

## 4219, 4229 or 4204

1. Insert self-tapping screws (provided) in two adjacent raised cabinet tabs. Leave the heads projecting 1/8".
2. Hang the unit on the screw heads via two of the slotted holes at the rear of its housing, as shown.
3. The 4219's or 4229's cover can be left off if the cover tamper jumper is placed in its upper (not tampered) position (see Detail C). The tampered cover is necessary for installations outside of the control's cabinet.

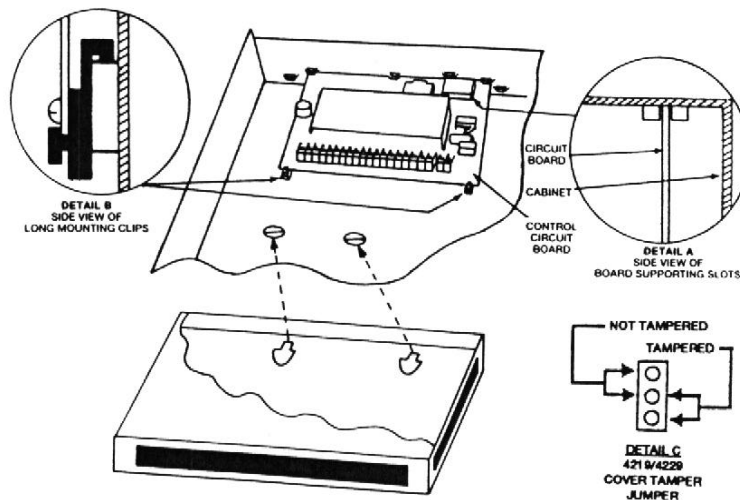

**Installing Control and RF Receiver Circuit Boards Together, In the Same Cabinet**

**IMPORTANT!**  
 Before installing the cabinet's contents, be sure to remove the appropriate metal cabinet knockouts.  
 DO NOT ATTEMPT TO REMOVE THE KNOCKOUTS AFTER THE CIRCUIT BOARDS HAVE BEEN INSTALLED.

1. Hang two *short* (black) mounting clips (provided with receiver) on the raised cabinet tabs, as shown in Detail B below.
2. Insert the top of the receiver board (removed from its own case as described in *its* instructions) into the slots at the top of the cabinet (see Detail A). Make sure that the board rests on the correct row of tabs.
3. Swing the base of the board into the mounting clips and secure it to the cabinet with the accompanying screws (see Detail B).
4. Insert the top of the control's board into the slot in the clips and position two *long* (red) clips at the lower edge of the board (see Detail C).
5. Swing this board into place and secure it with two additional screws.
6. Insert grounding lugs (supplied with the receiver) through the top of the cabinet into the *left-hand* terminals of the antenna blocks (at the upper edge of the receiver board) and secure them to the cabinet top with the screws provided, as shown in Detail D.
7. Insert the receiver's antennas through the top of the cabinet, into the blocks' *right-hand* terminals, and tighten the screws.

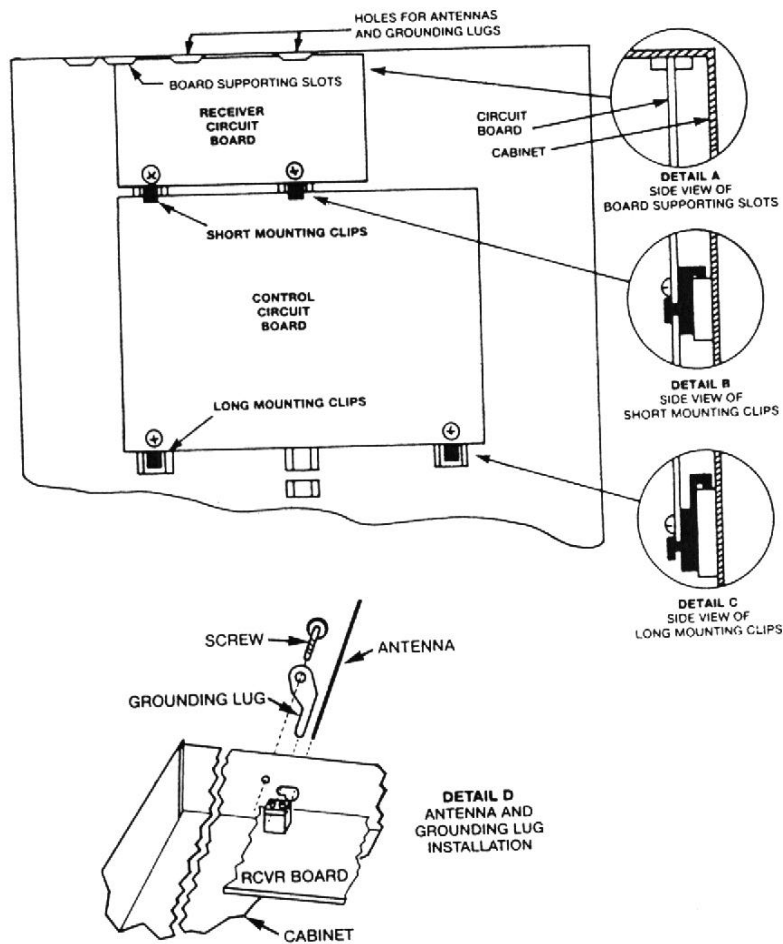

## Section 4. WIRING & POWERING THE SYSTEM

(See Summary of Connections Diagram on Page 47)

**IMPORTANT:** Do not connect the battery, or plug in the AC transformer, until all other wiring connections have been completed.

### Grounding the System

Terminal 21 is the earth ground connection point. In order for the protective devices in this product to be effective, the designated terminal must be terminated in a good earth ground. The following are examples of good earth grounds available at most installations:

**Metal cold water pipe:** Use a non-corrosive metal strap firmly secured to the pipe to which the lead is electrically connected and secured.

**AC power outlet ground:** Available from 3-prong, 120 VAC power outlets only. To test the integrity of the ground terminal, use a 3-wire circuit tester with neon lamp indicators, such as the UL Listed Ideal Model 61-035, or equivalent, available at most electrical supply stores.

### Terminals and Connections

1 & 2: AC Input (16.5VAC, 25VA) from No. 1321/TF2 plug-in transformer (in U.S.A.).

**Note:** For Canadian installations, a No. 1321CN transformer must be used.

3: Alarm relay output(+), 12VDC, 2.0A maximum  
(600mA max Alarm plus Aux Power for UL usage).

4: Alarm Output/Auxiliary Power/Wired Fire/Partition 1 Console(s)/ Optional 4281, 5881, 4219, 4229, or 4204 (BLACK lead). Ground (-) Return†.

5: Auxiliary/Wired Fire/Partition 1 Console(s)/Optional 4281, 5881, 4219, 4229, or 4204 (RED lead) Power: +12VDC at 500mA max †.

6: Data In from Partition 1 Console(s)/Optional 4281, 5881, 4219, 4229, or 4204 (GREEN)†.

7: Data Out to Partition 1 Console(s)/Optional 4281, 5881, 4219, 4229, or 4204 (YELLOW)†.

8: Zone 1. (When Zones are used, a 1,000 Ohm EOLR should be wired between the farthest sensor connected to the zone terminal and the low side of the zone.)

9: Zones 1 and 2 Return

10: Zone 2

11: Zone 3

12: Zones 3 and 4 Return

13: Zone 4

14: Zone 5.

15: Zones 5 and 6 Return.

16: Zone 6

17: Handset (TIP).

18: Handset (RING).

19: Incoming Phone Line (TIP).

20: Incoming Phone Line (RING).

21: EARTH GROUND (a proper earth ground must be provided to protect the system from lightning and electrostatic discharge damage).

**Warning:** To prevent the risk of electrical shock, disconnect the telephone line at the Telco jack before servicing the unit.

**RED LEAD:** Battery (+). When AC is present, 13.8VDC is being developed to recharge a gel lead acid battery and when AC is absent, 12VDC current is drawn from the battery. Battery lead reversal will blow the battery fuse.

**BLACK LEAD:** Battery (-).

† Up to 4 consoles may be used per partition (check total auxiliary current, per SPECIFICATIONS). Consoles need not necessarily be on individual home runs, but no more than 220' of #22 wire or 550' of #18 wire should be used for each run.

Addressable consoles (e.g., 4137AD and 5137AD) may be used, if they are set to their non-addressable mode (device ID 31...all DIP switch positions UP).



### **Power-up Procedure**

1. Make sure that the total current to be drawn from the Alarm Output terminals (3 & 4) and Auxiliary Power Output terminals (4 & 5) does not exceed the values indicated in the *SPECIFICATIONS* section and on the *SUMMARY OF CONNECTIONS* diagram.
2. Wire the transformer to the panel (before connecting the battery) as shown on the *SUMMARY OF CONNECTIONS* diagram. **Do not plug in at this time.**
3. Connect all loops, devices, consoles, etc. to the panel.
4. Plug the transformer into a 24 hour, uninterrupted AC outlet. After some initial displays (see page 22) and approximately one minute, the green POWER or READY LED on the console(s) should be lit and the consoles should display "READY" (Fixed Word consoles) or "DISARMED READY TO ARM" (Alpha consoles).
5. Connect the battery as shown in the *SUMMARY OF CONNECTIONS* diagram.

# Section 5. SYSTEM OPERATION

## SECURITY CODES

### Installer Code

The installer programs the 4-digit Installer Code initially as part of the programming procedure (see *PROGRAMMING THE SYSTEM*). The factory default Installer code is "4111".

The Installer code can permit re-entry into the programming mode and also, in normal operation mode, is used to enter the Master code for each partition, which allows access to the normal functions of the system.

See the *PROGRAMMING THE SYSTEM* section for information on exiting the programming mode via fields \*98 or \*99.

### Master Codes

In normal operation mode, the Installer code is used to enter the 4-digit Master security code for each partition, via the console connected to Partition 1:

To enter the Master code for Partition 1, enter:

Installer Code + [CODE key] + [1] + desired Master code for Partition 1

To enter the Master code for Partition 2, enter:

Installer Code + [CODE key] + [2] + desired Master code for Partition 2

### Secondary User Codes

In normal operation mode, each partition's Master security code can be used to assign up to two secondary security codes for that partition. It can also be used to remove secondary codes from the system (individually).

To assign (or change) a Secondary security code, enter (via partition's console):

Partition's Master Code + [CODE key] + User # (3 or 4) + desired Secondary Code

The system will emit a single beep when each secondary code has been successfully entered.

To delete a Secondary security code, enter (via partition's console):

Partition's Master Code + [CODE key] + User # (3 or 4)

### Notes:

- All Master and Secondary security codes permit access to the system for arming, disarming, etc.
- The installer code can disarm the system only if it was used to arm it.
- If a secondary code is inadvertently repeated for different users, or one user's code is another's duress code (4th digit increased by 1), the lower user number will take priority.
- Opening and closing reports are sent for the Installer code as No. 1, with the appropriate subscriber number. Each Master code and set of Secondary user codes are sent as Nos. 2, 3, and 4 respectively, with the appropriate subscriber number.

## KEYPAD FUNCTIONS

### General Information

Note that if QUICK ARM is enabled for the partition (field \*21), the [#] key can be pressed instead of entering the partition's security code, for any of the arming procedures (Away, Stay, Instant, Maximum, etc.). The security code is *always* required, however, when disarming the system.

The keypad allows the user to arm and disarm the system, and perform other system functions, such as bypassing zones, and display zone descriptors. Zone and system conditions (alarm, trouble, bypass) are displayed in the Display Window.

When an alarm occurs, console sounding and external sounding will occur, and the zone(s) in alarm will be displayed on the console. Pressing any key will silence the console sounder for 10 seconds. Disarming the system will silence both console and external sounders. When the system is disarmed, any zones that were in an alarm condition during the armed period will be displayed (memory of alarm). To clear this display, simply repeat the disarm sequence (enter the security code and press the OFF key) *twice*.

The consoles also feature chime annunciation, and 3 panic key pairs (for silent, audible, fire or personal emergency alarms) which can notify the central station of an alarm condition, if that service is connected.

## Arming Functions

The following is a brief list of system commands. For detailed information concerning system functions, refer to the User's Manual.

|                              |  |
|------------------------------|--|
| <b>Disarmed, Not Ready</b>   | Before arming, the system must be in the READY condition (all zones must be intact). If the "NOT READY" message appears, press the READY [*] key to display faulted zones. |
| <b>Arming Away</b>           | Enter code + AWAY [2].   |
| <b>Arming Stay</b>           | Enter code + STAY [3].   |
| <b>Arming Instant</b>        | Enter code + INSTANT [7].  |
| <b>Arming Maximum</b>        | Enter code + MAXIMUM [4].  |
| <b>Disarming</b>             | Enter code + OFF [1].  |
| <b>Bypassing Zones</b>       | Enter code + BYPASS [6] + zone number(s).  |
| <b>Forced (Quick) Bypass</b> | <i>(If enabled)</i> To automatically bypass all faulted zones, use "Quick Bypass" method:<br>Enter code + BYPASS (then stop).  |
| <b>Chime Mode</b>            | Enter code + CHIME [9].<br>To turn chime mode off, enter code + CHIME again.   |

### SUMMARY OF ARMING MODES

| Mode    | Features for Each Arming Mode |             |                 |                |
|---------|-------------------------------|-------------|-----------------|----------------|
|         | Exit Delay                    | Entry Delay | Perimeter Armed | Interior Armed |
| AWAY    | Yes                           | Yes         | Yes             | Yes            |
| STAY    | Yes                           | Yes         | Yes             | No             |
| INSTANT | Yes                           | No          | Yes             | No             |
| MAXIMUM | Yes                           | No          | Yes             | Yes            |

## Panic Keys

There are three panic key pairs and (on some consoles) lettered keys (shown below) that, if programmed, can be used to manually initiate alarms and send a report to the central station. Each can be individually programmed for 24 Hour Silent, Audible, Personal or Fire Emergency responses. The panic function is activated when both keys of the appropriate key pair is pressed at the same time, or the appropriate lettered key is pressed for at least 2 seconds.

The panic functions are identified by the system as follows:

| KEYS              | Displayed as Zone |
|-------------------|-------------------|
| [1] & [*], or [A] | 95                |
| [*] & [#], or [B] | 07                |
| [3] & [#], or [C] | 96                |

**Notes:**

- Keys [A], [B], [C] are not on all consoles.
- Key [D], if present, is not active here.

**IMPORTANT:** For the Panic functions to be of practical value, the system must be connected to a central station.

## TROUBLE CONDITIONS

### General Information

The word "CHECK" on the Console's display, accompanied by a rapid "beeping" at the Console, indicates that there is a trouble condition in the system. The audible warning sound can be silenced by pressing any key. Instruct users to call for service immediately upon seeing any of the following messages.

### "Check" and "Battery" Displays

- **A display of "CHECK" and one or more zone numbers** indicates that a problem exists with the displayed zone(s) and requires attention.

When the problem has been corrected, the display can be cleared by entering the OFF sequence (code plus OFF key) twice.

- **If there are wireless sensors in the system**, the CHECK condition may also be caused by some change in the environment that prevents the receiver from hearing a particular sensor.
- **A display of "BAT" with no zone number** indicates that the system's main standby battery is weak.
- **A display of "BAT" with a zone number and a once per minute "beeping" at the console** indicates that a low battery condition exists in the wireless sensor displayed (zone "00" indicates a wireless keypad). If the battery is not replaced within 30 days, a CHECK display may occur.

**Note:** Some wireless sensors contain a non-replaceable long-life battery which requires replacement of the entire unit at the end of battery life (e.g., Nos. 5802, 5802CP, 5803).

### Power Failure

- **If there is no console display at all, and the POWER indicator (if present) is not lit**, operating power for the system has stopped and the system is inoperative.
- **If the message "AC LOSS" or "NO AC" is displayed, and the POWER Indicator (if present) is off**, the console is operating on battery power only.

### Other Displays (Fixed Word Consoles)

- dI** If this remains displayed for more than 1 minute, the system is disabled.
- CC** The system is in communication with the central station for change of function or status verification.
- FC** A communication failure has occurred.
- OC** The console is not receiving signals from the control panel and sees an open circuit.

## Section 6. PROGRAMMING THE SYSTEM

### General Information

Installer options are stored in non-removable, electrically erasable, non-volatile EEROM memory. These options must be programmed for the particular installation to establish its specific alarm and reporting features.

**Note:** It is possible to program the system at any time, even at the installer's premises prior to the actual installation. Simply apply power temporarily to the control and then program the unit as desired.

**BOTH PARTITIONS OF THE SECURITY CONTROL ARE PROGRAMMED VIA A 5137 OR 6139 ALPHA CONSOLE CONNECTED TO PARTITION 1** (but it need not necessarily remain in the system after programming).

**Note:** A 5137AD (Addressable) Console may be used, provided it is set to its non-addressable mode (device ID 31...all DIP switch positions UP).

The initial sequence of entries should follow the order on the programming sheet.

*Certain programming fields, such as those used to select the expansion devices (fields \*22 and \*25) must be programmed before expansion zones can be programmed. If an expansion unit type is changed, the expansion zones should be reprogrammed.*

When programming, the field number will be displayed on the LCD display; also, each entry is displayed as it is keyed in. After programming, values that have been entered in each field can be reviewed and, if necessary, modified. When programming from the console, note the following:

1. Enter the programming mode by simultaneously depressing the [\*] and [#] keys **within 50 seconds after power is applied to the Control**, or subsequently by keying the code 4 + 1 + 1 + 1 followed by depression of **CODE + 0** keys. If a different installer code is subsequently programmed, use it instead of 4111 to gain access to the Programming mode. *If the Programming mode was exited previously using a \*98, it will prevent entry into the Programming mode by the use of the Installer Code + CODE + 0.*
2. Immediately following entry into the program mode, field \*20 will be displayed. Following the above display, the system is ready to accept entries for field \*20.
3. To program a data field, key [\*] plus **Field No.** (for example, \*21), then make the required entry.

Some entries require sequential pressings of [\*] to actually enter data. This is true in the Zone and Relay fields \*56, \*80, and \*81 and the prompts will indicate this. Entry of [#] will generally back up one entry position for review.

4. To simply review a data field, key [#] plus **Field No.**. Data will either be automatically sequentially displayed or can be displayed by successively pressing [#]. No changes will be accepted in this mode.
5. When a data field has been completely reprogrammed, the console will normally "beep" three times and then automatically proceed to, and display, the next data field number to be programmed (if not, key [\*] plus the **Field No.** of the next field to be programmed).
6. If the number of digits that you enter in the data field is less than the maximum permitted, (for example, phone number), then the console will display the last data entered. To proceed, the next data field number to be programmed must then be entered (for example, \*42).
7. If a field is improperly entered, the console will display **EE**. Simply re-enter [\*] or [#] plus the field number.

**Summary of  
Programming  
Commands**

**IMPORTANT**  
The 4111XM can only be put into the Programming Mode via Partition 1 consoles and only while both partitions are disarmed.

| FUNCTION               | PROCEDURE   |
|------------------------|---|
| ENTER PROGRAMMING MODE | 1. POWER UP, then depress [*] and [#] both at once, within 50sec of powering up.<br><b>OR</b><br>2. Initially, key: 4 +1 + 1 +1 plus CODE key + 0.<br><b>OR</b><br>3. If different Installer Code is programmed, key :<br><b>Installer CODE + CODE Key + 0</b><br>(if *98 was used to exit previously, method 1 above must be used to enter the program mode again) |
| EXIT PROGRAMMING MODE  | *99 allows re-entry to programming mode via type 2 or 3 entry method above.<br>*98 inhibits re-entry to programming mode via type 2 or 3 entry method.  |
| ADVANCE TO FIELD       | [*] + Field No. (e.g., 21, 38, 56, etc.)  |
| PROGRAM FIELD          | [*] + Field No., followed by data entries. Some fields require sequential pressings of [*] to enter data (e.g., fields 56, 80,81).  |
| ERASE FIELDS           | [*] + Field No. + [*] (only applies to fields 40 thru 44 and 94).   |
| READ FIELD             | [#] + Field No. Data will either be automatically sequentially displayed or can be displayed by successively pressing [#].  |

**Special Messages**

OC = OPEN CIRCUIT (no communication between Console and Control).

EE = ERROR (program entry mistake). Re-enter the field number or data).

After powering up, AC, dl (disabled) or System Busy and NOT READY will be displayed after approximately 4 seconds. This will revert to READY in appx. 1 minute, which allows PIRS, etc. to stabilize. To bypass this delay, press: [#] + [0].

If E4 or E8 appears, more zones than the expansion units can handle have been programmed. Correct the program and then completely de-power and re-power the control to clear this indication and remove the disable indication.

# PROGRAMMING DATA FIELDS

THE CENTERFOLD PROGRAMMING FORM CAN BE USED TO RECORD THE DATA FOR THIS INSTALLATION

- SYSTEM ARMING (\*20-\*25)**
  - \* 20 MASTER CODE**  
Enter 4 digits, 0-9 (entry of all 4 is mandatory).  
Use of a "9" in the last position inhibits the Ambush feature.
  - \* 21 QUICK ARM ENABLE**  
If enabled, [#] key can be used instead of security code when arming the system.  
Enter 0 for disabled or 1 for enabled for each partition.
  - \* 22 RF SYSTEM TYPE**  
Select the RF system (receiver) type being used.  
0 = none; 1 = 5700 (4281); 2 = 5800 (5881)
  - \* 23 FORCED BYPASS FUNCTION**  
All zones that are bypassed by this function will be displayed after the bypass is initiated. Enter, for each partition:  
0 = No forced bypass.  
1 = Allows automatic bypass of all open zones.
  - \* 24 RF RECEIVER HOUSE ID CODE**  
MUST enter for 5700 system, or 5827 Keypad (on 5800 system).  
For 5827 only: Partition 2 House ID = Entered (Partition 1) ID + 1  
Enter 01-31 House ID.
  - \* 25 WIRED EXPANSION/OUTPUT RELAY USED**  
Select expansion/relay unit being used.  
0 = none; 1 = 4219; 2 = 4229; 3 = 4204
- ZONE SOUNDS AND TIMING (\*28-\*39)**
  - \* 28 SINGLE ALARM SOUNDING PER ZONE (per armed period)**  
Enter 0 for no or 1 for yes
  - \* 29 FIRE SOUNDER TIMEOUT DISABLE**  
Enter 0 to enable the sounder timeout for fire or 1 to disable it.
  - \* 30 ALARM BELL TIMEOUT**  
External sounder will shut off after time allotted. Enter 1 digit.  
0 = No timeout      2 = 8 minutes  
1 = 4 minutes        3 = 12 minutes
  - \* 38 ENTRY DELAY**  
System will wait the time allotted before sounding alarm upon entering.  
Enter 1 digit for each Partition.  
(EXIT delay = Entry delay plus 15 seconds)  
0 = 0 seconds      2 = 30 seconds  
1 = 20 seconds     3 = 45 seconds
  - \* 39 ZONE 3 RESPONSE TIME TO OPEN**  
0 = 400 ms nominal  
1 = 10 ms nominal
- DIALER PROGRAMMING (\*40-\*50)**
  - \* 40 PABX ACCESS CODE**  
Enter 4 digits, 0-9, for each PABX digit needed to access an outside line.  
To skip this field, enter \*. If \* is entered, no PABX number will be dialed and nothing will appear in this field. End field by entering \*41 if not filled.  
To clear entries from field, press \*40\*.
  - \* 41 PRIMARY PHONE No.**  
Enter up to 12 digits, 0-9. Do not fill unused spaces. End field by entering \*42 if not filled. To clear entries from field, press \*41\*.  
**Note:** Back-up reporting (8 calls are made to the secondary phone number if no kiss-off is received after 8 attempts to the primary number) is automatic only if there is a secondary phone number.
  - \* 42 SECONDARY PHONE No.**  
See field \*41 entry info. and Note. End field by entering \*43 if not filled.  
To clear entries from field, press \*42\*.

- \* 43 **PARTITION 1 SUBSCRIBER ACCOUNT. No.**  
See Field \*44.
- \* 44 **PARTITION 2 SUBSCRIBER ACCOUNT. No.**  
*For Fields \*43 and \*44.*  
Enter digits 0-9; #+11=B; #+12=C; #+13=D; #+14=E; or #+15=F.  
Enter \* as the fourth digit if a 3 digit acct no. (for 3+1 dialer reporting format) is used. Enter 0 as the first digit of a 4-digit acct no. for nos. 0000-0999. End field by pressing \* (and press next field) if only 3 digits are used. To clear entries from field, press \*43\* or \*44\*.
- \* 45 **PHONE SYSTEM SELECT**  
Enter 1 digit.  
If Central Station Rcvr is *not* on WATS line:  
0 = Pulse Dial    1 = Tone Dial  
If Central Station Rcvr is on WATS line:  
2 = Pulse Dial    3 = Tone Dial
- \* 46 **REPORT FORMAT**  
Determine which format is to be used to report to the central station.  
Enter 1 digit.  
0 = 3+1; 4+1 ADEMCO L/S Standard  
1 = 3+1; 4+1 Radionics Standard  
2 = 4+2 ADEMCO Lo Speed Standard  
3 = 4+2 Radionics Standard  
6 = 4+2 ADEMCO Express  
7 = ADEMCO Contact ID Reporting  
8 = 3+1; 4+1 ADEMCO Lo Speed Expanded  
9 = 3+1; 4+1 Radionics Expanded  
(Enter \* as the 4th digit of \*43, if 3+1 dialer reporting is to be used.)  

*For explanation of these formats, see page 33.*

  
**Note:** The maximum number of communicator reports during one armed period is 10.
- \* 47 **SPLIT/DUAL REPORTING**  
Enter 0 to disable (Backup report only)  

|     | TO PRIMARY                  | TO SECONDARY     |
|-----|-----------------------------|------------------|
| 1 = | Alarms, Restore, Cancel     | Others           |
| 2 = | All except Open/Close, Test | Open/Close, Test |
| 3 = | Alarms, Restore, Cancel     | All              |
| 4 = | All except Open/Close, Test | All              |
| 5 = | All                         | All              |
- \* 48 **15 SECOND DIALER DELAY (BURGLARY)**  
Allows time for subscriber to avoid a false alarm transmission.  
Enter 0 for no or 1 for yes
- \* 49 **PERIODIC TEST MESSAGE**  
Select the desired test report interval.  
0 = none; 1 = 24 hours; 2 = weekly  
Test Report Code entered in field \*64 is sent.  
Reports with Partition 1 Subscriber No.
- \* 50 **SESCOA/RADIONICS SELECT**  
0 = Radionics (0-9, B-F reporting)  
1 = SESCOA (0-9 only reporting)
- \* 51 **CONFIRMATION OF ARMING DING**  
Enter 0 for no or 1 for yes, for each partition.  
If selected, ding is external sounder only and will occur at time of kissoff of closing report. If closing report is not programmed, ding will occur at end of exit time.

**ARMING DING  
(\*51)**



**ZONE ASSIGNMENT/  
ALARM REPORT  
CODES, etc.  
(\*56)**

\*56

**ZONE ASSIGNMENT/ALARM REPORT CODES  
(and RF Input ID Learning for 5800 System)**

*REFER TO THE ZONE ASSIGNMENT TABLE FOR THIS FIELD  
IN THE CENTERFOLD PROGRAMMING FORM.*

This field is used to program zone numbers, zone types, partition numbers, alarm and report codes, and to identify the type of loop input device. This field can also be used for "learning" 5800 series transmitter ID codes and for entering alpha descriptors for zones.

**Zone Number (Zn)**

Upon entering field \*56, enter the zone number that you wish to program (or [0][0] to leave zone programming).

Press [\*]. A summary display will come up, showing the status of that zone's program.

If it is programmed satisfactorily, press [#] to back up one step and enter another zone number, if desired.

If the zone is not programmed, or you want to change it, press [\*]. A prompt for Zone Type will appear.

**Zone Type (ZT)**

Enter the zone type code (or change it, if necessary). Default values for zones 01 to 07 are:

|               |      |      |      |      |      |      |      |
|---------------|------|------|------|------|------|------|------|
| Zone No.(Zn): | 01   | 02   | 03   | 04   | 05   | 06   | 07   |
| (ZT) Default: | [01] | [04] | [03] | [03] | [09] | [07] | [06] |

When the display shows the zone type you want, press [\*] to advance to...

**Partition No. (P)** (Default = [1], zones 01-06)

Enter "1" or "2" and press [\*] to advance to...

**Report Code (RC)**

The report code consists of 2 hexadecimal digits, each in turn consisting of 2 numerical digits. For example, for a report code of "3C", enter [0][3] for "3" and [1][2] for "C". Enter the numbers and press [\*] to advance to...

**Input Device (In)**

For the hard wired zones of the 4111XM (HW), the auxiliary wired expansion zones on a 4219 or 4229 (AW), and the zones for a 5700 system's transmitters (RF), the Input Device types are automatically displayed (Panic, Duress, and Tamper inputs are not applicable). For a 5800 system's transmitters, "RF" is initially displayed, but should be changed to "UR" (Unsupervised RF, enter 4) for units that can be carried off-premises, or to "BR" (Button type RF, enter 5) for small transmitters that cannot be supervised. Check the instructions that come with the transmitter for the proper input. When all is okay, press [\*] to advance to...

**Learned RF Input (L)**

**Note:** Where a "Yes-No" is asked by the console, pressing the [\*] or [0] for No is equivalent.

*Applicable to a 5800 system only*

This request will be to learn the transmitter input's ID code. (The ID codes can be learned here or via field \*83.)

If "yes" is selected, open and close (or close and open), or press and release the particular input to the transmitter twice. After the first time, a single short beep will occur. After the second time, two short beeps will mean that the control has accepted that transmitter into the system. Because of the characteristics of the receiver, allow about 8 seconds between transmissions from button units. If a long beep occurs, it means that the particular transmitter input has previously been registered in the system.

*Mark the zone number on the transmitter.*

If all is okay, press [\*].

### Custom Alpha Editing

For all zone types, the next request is to enter alpha descriptors for the zones. The entry may be done now or may be done at a later time via field \*82.

See the ALPHA DESCRIPTION ENTRIES section on page 30.

---

When all entries to be made for the zone at this time are complete, the next zone number can be entered for programming, or zone programming can be ended by entering [0][0] as the next "zone number".

**Notes:**

- *When using a 5801, the Function "4" button should always be used and learned by the system.*
- *In field \*56, at the summary line for each zone, the entered values can be checked. If it is desired to change anything, press [#] to move to the previous entry. Press [#] a number of times to move to earlier entries. Press [\*] to move to later entries again.*
- *Zone entries can be reviewed by pressing [#][5][6]. Changes cannot be made here, so this is safer for review. Enter the first zone number to be viewed and press [#]. To view each zone, press [#] and the zone number will advance to the next programmed zone. When the end of the list is reached, press [0][0] to exit. This method of exiting may also be done at any time during the review.*
- *To either temporarily or permanently remove a zone from the system, go into programming mode and press [\*][5][6]. Enter the zone number and press [\*]. At the Zone Type prompt, enter [0][0] and [\*]. This sets the type of the zone to Not Used. The next prompt will be "Delete Zone?". "Yes" will permanently remove the zone from the system while "No" will disable it but retain all data except the original zone type. You can then go back to this zone later and put back an active Zone Type to re-enable it.*
- *An ID code that has been learned for a 5800 system will not be deleted if the zone is disabled as described above. If only the physical transmitter is to be removed or changed (i.e., its ID code deleted), it can be done in field \*56 or \*83. In programming mode, press [\*][5][6], enter the zone number, and press [\*] multiple times until the cursor is under the Learned RF Input (L) position. This is the specific loop or button on the transmitter that has been learned for that zone. If a [0] is entered at this point, a prompt "Delete S/N?" will appear. If "Yes" is entered, this specific ID code will be deleted from the system.*

**Example of  
Output Relay  
Programming**

**FOR OTHER EXAMPLES  
SEE THE TABLE  
ON PAGE 44**

Let us light an indicator when any one of 3 specific zones are faulted or when any 24 hour aux. zone is disturbed. We want to turn off the indicator manually without affecting the arming status of the system.

In field \*80 we choose Output Relay 01 and program the Action (A) to be "2" (Close and stay closed). The Event we are looking for to start the relay action is a fault, so we will program "2" in (EV). We will use Zone List 1 for the 3 specific zones, so will program "1" in (ZL), (and will program these 3 zones in field \*81's Zone List 1).

The second condition for turning on the indicator is triggering a 24 hour aux. zone (Zone Type 08), so we will program (ZT) as "08".

To stop the relay action and turn off the indicator, we do not want to use a restore of any zone, so we will program a "0" for the Restore of Zone List (ZL). We will choose a manual entry of User Code + [#] + [7] to turn it off, so will program (ZT) as "34".

If no other relay is to be programmed we go to field \*81 and program the 3 specific zones in Zone List 1.

**\* 81 ZONE LISTS FOR OUTPUT RELAYS**

*Applicable only if field \*25 is programmed for a 4229 or 4204...otherwise skip this field.*

**Zone List Displays ↓**

Zone List No.  
(00 = Quit) 01

Upon entering field \*81, this screen will appear. Enter the Zone List Number 01, 02, or 03 to program (or 00 to end these entries). Press the [\*] key to advance.

03 Enter Zn Num.  
(00 = Quit) 00

In the following displays, zone list 03 has been selected for programming.

Enter each zone number to add to the zone list by first entering the zone number, then the [\*] key (ex., 01\*, 02\*, 03\*). After all zones desired are entered, enter 00 to advance.

03 Del Zn List?  
0 = No 1 = Yes 0

To delete the zone list, enter 1 (Yes). All zones in the zone list will be deleted automatically. and programming will return to the first screen.

To save the zone list, enter 0 (No) to advance.

03 Delete Zone?  
0 = No 1 = Yes 0

To save the entire zone list, enter 0 (No) and programming will return to the first screen.

To delete a zone or zones in a zone list enter 1 (Yes) to advance.

03 Zn to Delete?  
(00 = Quit) 00

Enter each zone to be deleted from the list, followed by the [\*] key. After all zones to be deleted are entered, enter 00 to return to the first screen so that another list can be programmed, if desired.

- Notes:**
- Any list may include any or all of the system's zone numbers.
  - A zone list can be assigned to more than one output relay.
  - If you only want to review what has been programmed previously, enter [#][8][1]. The review can be advanced by using the [#] key. When finished, enter [0][0] to quit. No programmed values can be disturbed in this mode.

**\* 82 CUSTOM ALPHA EDITING**

(Also entered from field \*56)

*See ALPHA DESCRIPTION ENTRIES section on page 30.*

**\* 83 ADD/DELETE 5800 RF INPUT IDs**

See procedure in last paragraph of field \*56.

**\* 94 DOWNLOAD PHONE NUMBER**

Enter up to 12 digits; 0-9. Do not fill unused spaces. End field by entering \*. To clear entries from field, press \*94\*.

**\* 95 RING DETECTION COUNT FOR  
DOWNLOADING**

Enter number of rings before control picks up phone line (or 0 or 15).

- 0 = disable station initiated download
- 1-14 = # of rings
- 15 = answering machine defeat

**DOWNLOAD  
INFORMATION  
(\*94, \*95)**

- \*96 INITIALIZE DOWNLOAD ID AND SUBSCRIBER ACCT. No. FOR DOWNLOADING  
(No data entry required, loads defaults)
- \*97 SET ALL PROGRAM FIELDS TO DEFAULT VALUES  
(No data entry required)

Press \*98 or \*99 if exiting programming, or next Field No. if continuing.

**TO EXIT  
PROGRAMMING MODE  
(\*98 or \*99)**

- \*98 EXITS PROGRAMMING MODE  
and prevents re-entry by :  
Installer Code + CODE + 0
- \*99 EXITS PROGRAMMING MODE  
and allows re-entry by:  
Installer Code + CODE + 0  
or by:  
Power-up + "" + "#".

## ALPHA DESCRIPTION ENTRIES

See the ALPHA FIXED DICTIONARY and CHARACTER CHART on page 32.

### Assigning Zone Descriptors

The Alpha Console used with the 4111XM can have a user-friendly English language description/location of all protection zones, keypad panics, and RF receiver supervision faults programmed into the system. Each description can be composed of a combination of words (up to a maximum of 3) selected from a vocabulary of 244 words stored in memory (see page 32). In addition, up to 5 installer-defined words can be added to those already in memory. Thus, when an alarm or trouble occurs in a zone, an appropriate description for that zone's location will be displayed at the console.

**Note:** Alpha Descriptor entry can be done locally at the Alpha Console or remotely using a 4130PC Downloader. The Alpha Console procedure is described below.

### Entering Zone Descriptors

1. The descriptor can be entered when the zone is being defined in field \*56 or it can be entered later, in field \*82.

The console keys perform the following functions:

- [3] Scrolls both alphabet and actual words in *ascending* alphabetical order.
- [1] Scrolls both alphabet and actual words in *descending* alphabetical order.
- [6] Toggles between alphabet and actual word list; used to accept entries.
- [8] Saves the zone description in the system's memory.

2. Key [\*][0][1] to begin entering the description for zone 1 (key [\*][0][2] for zone 2, [\*][0][3] for zone 3, etc.). *If nothing was entered previously*, the following will be displayed: \* ZN 01 A

Note that the first letter of the alphabet appears after the zone number, and that the zone number is automatically included with the description. *If there already is a description for the zone*, the description will appear (with no cursor, since this is a display mode). *If it is desired to enter or change a description*, key in [\*] + Zone Number again. A flashing cursor will now appear.

3. **One of two methods of entering the words can now be used** (assume, for example that the desired description for zone 1 is BACK DOOR) :
  - a) **Press [#] followed by the 3 digit number of the first word from the fixed dictionary shown on page 32** (e.g., [0][1][3] for BACK). Press [6] in order to save the word and proceed, or...
  - b) **Select the first letter of the desired description** (note that "A" is already displayed). Press key [3] repeatedly to advance through the alphabet (e.g., to "B"), or key [1] to go backward. Then press [6] to display the first available word beginning with the desired letter (e.g., BABY). Next, press [3] repeatedly to move forward, or [1] to move backward, until the desired word is displayed (e.g., BACK). Then press [6] to accept the word and toggle back to the alphabet list.

4. For selection of the next word (e.g., DOOR), repeat steps 3a or 3b. For 3b, press key [3] until the first letter of the next word appears (e.g., "D"). Then press [6] to display the first available word beginning with that letter (e.g. DAUGHTERS). Press [3] repeatedly until the desired word (e.g., DOOR) appears. To accept the word, press [6], which toggles back to the alphabet list.
5. When all desired words have been entered, press [8] to store the description in memory.
6. In field \*56, the next zone number in sequence will now be displayed for complete zone information entry.  
In field \*82, enter [\*][N][N], where NN is the next zone that you want to review or for which you want to program a descriptor. To modify the descriptor, enter [\*][N][N] again. To exit this mode, press [\*][0][0].

### **Adding Custom Words**

Up to five installer-defined words can be added to the built-in vocabulary. Each of the five "words" can actually consist of a "word string" of several words, but no more than ten characters can be used for each word or word string.

1. Select CUSTOM WORD mode when the question arises.  
The console keys perform the following functions:  
[3] Advances through alphabet in ascending order.  
[1] Moves through alphabet in descending order.  
[6] Selects desired letter; moves cursor one space to right.  
[4] Moves cursor one space to left.  
[7] Inserts a space at the cursor location, erasing any character located there.  
[8] Saves the new word in the system's memory.
2. Key the number ([1]–[5]) of the custom word or word string to be created (for example, if you are creating the first custom word or word-string, enter [1], for the second, enter [2], etc.). A cursor will now appear at the beginning of the second line.
3. **One of two methods of entering the custom word's characters can now be used** (refer to the CHARACTER LIST of letters, numbers, and symbols on the next page):  
**Important:** Custom words must begin with an *alphabetic* character. If a number or symbol is used as the first character, the word will not be saved.
  - a) Press the [#] key, followed by the two digit entry for the first letter you would like to display (e.g., [6][5] for "A"), or...
  - b) Use the [3] key to advance through the list of symbols, numbers, and letters. Use the [1] key to move back through the list.
4. When you have reached the desired character, press [6] to select it. The cursor will then move to the right, in position for the next character.
5. Repeat steps 3 and 4 to create the desired word(s). Note that the [4] key can be used to move the cursor to the left, if necessary, and that key [7] can be used to enter a blank (or erase an existing character). Remember, no word or word-string can exceed 10 characters.
6. Press the [8] key to save the custom word(s) and return to the "CUSTOM ?" display. Repeat steps 2-5 for other custom words to be entered. To change a custom word, just overwrite it. If no more are to be entered now, press [0] to return to the Descriptor entry. The custom word(s) will be automatically added to the built-in vocabulary.

When zone descriptors are being entered as described in step 3a of the *Entering Zone Descriptors* section, the custom word numbers are 250 to 254 for words 1 to 5 respectively. When being entered as described in step 3b of that section, each word will be found at the end of the group of words that begin with the same letter as it does.

# ALPHA FIXED DICTIONARY

(For Entering Zone Descriptors)

|                  |                   |               |                   |                    |
|------------------|-------------------|---------------|-------------------|--------------------|
| 000 (Word Space) | 054 DISCRIMINATOR | 105 KITCHEN   | 155 RADIO         | 209 VALVE          |
| 001 AIR          | 055 DISPLAY       |               | 156 REAR          | 210 VAULT          |
| 002 ALARM        | 056 DOCK          | 106 LAUNDRY   | 157 RECREATION    | 211 VIBRATION      |
| 003 ALCOVE       | 057 DOOR          | 107 LEFT      | 158 REFRIG        | 212 VOLTAGE        |
| 004 ALLEY        | 058 DORMER        | 108 LEVEL     | 159 REFRIGERATION |                    |
| 005 AMBUSH       | 059 DOWN          | 109 LIBRARY   | 160 FF            | 213 WALL           |
| 006 AREA         | 060 DOWNSTAIRS    | 110 LIGHT     | 161 RIGHT         | 214 WAREHOUSE      |
| 007 APARTMENT    | 061 DRAWER        | 111 LINE      | 162 ROOM          | 215 WASH           |
| 008 ART          | 062 DRIVEWAY      | 112 LIQUOR    | 163 ROOF          | 216 WEST           |
| 009 ATTIC        | 063 DRUG          | 113 LIVING    |                   | 217 WINDOW         |
| 010 AUDIO        | 064 DUCT          | 114 LOADING   | 164 SAFE          | 218 WINE           |
| 011 AUXILIARY    |                   | 115 LOCK      | 165 SCREEN        | 219 WING           |
|                  | 065 EAST          | 116 LOOP      | 166 SENSOR        | 220 WIRELESS       |
| 012 BABY         | 066 ELECTRIC      | 117 LOW       | 167 SERVICE       | 221 WORK           |
| 013 BACK         | 067 EMERGENCY     | 118 LOWER     | 168 SHED          |                    |
| 014 BAR          | 068 ENTRY         |               | 169 SHOCK         | 222 XMITTER        |
| 015 BARN         | 069 EQUIPMENT     | 119 MACHINE   | 170 SHOP          |                    |
| 016 BASEMENT     | 070 EXECUTIVE     | 120 MAGNETIC  | 171 SHORT         | 223 YARD           |
| 017 BATHROOM     | 071 EXIT          | 121 MAIDS     | 172 SHOW          |                    |
| 018 BED          | 072 EXTERIOR      | 122 MAIN      | 173 SIDE          | 224 ZONE (No.)     |
| 019 BEDROOM      |                   | 123 MASTER    | 174 SKYLIGHT      | 225 ZONE           |
| 020 BELL         | 073 FACTORY       | 124 MAT       | 175 SLIDING       |                    |
| 021 BLOWER       | 074 FAILURE       | 125 MEDICAL   | 176 SMOKE         | 226 0              |
| 022 BOILER       | 075 FAMILY        | 126 MEDICINE  | 177 SONIC         | 227 1              |
| 023 BOTTOM       | 076 FATHERS       | 127 MICROWAVE | 178 SONS          | 228 1ST            |
| 024 BOX          | 077 FENCE         | 128 MONEY     | 179 SOUTH         | 229 2              |
| 025 BREAK        | 078 FILE          | 129 MONITOR   | 180 SPRINKLER     | 230 2ND            |
| 026 BUILDING     | 079 FIRE          | 130 MOTHERS   | 181 STAMP         | 231 3              |
| 027 BURNER       | 080 FLOOR         | 131 MOTION    | 182 STATION       | 232 3RD            |
|                  | 081 FLOW          | 132 MOTOR     | 183 STEREO        | 233 4              |
| 028 CABINET      | 082 FOIL          | 133 MLD       | 184 STORE         | 234 4TH            |
| 029 CALL         | 083 FOYER         |               | 185 STORAGE       | 235 5              |
| 030 CAMERA       | 084 FREEZER       | 134 NORTH     | 186 STORY         | 236 5TH            |
| 031 CAR          | 085 FRONT         | 135 NURSERY   | 187 STRESS        | 237 6              |
| 032 CASE         | 086 FUR           |               | 188 STRIKE        | 238 6TH            |
| 033 CASH         | 087 FURNACE       | 136 OFFICE    | 189 SUMP          | 239 7              |
| 034 CCTV         |                   | 137 OIL       | 190 SUPERVISED    | 240 7TH            |
| 035 CEILING      | 088 GALLERY       | 138 OPEN      | 191 SUPERVISION   | 241 8              |
| 036 CELLAR       | 089 GARAGE        | 139 OPENING   | 192 SWIMMING      | 242 8TH            |
| 037 CENTRAL      | 090 GAS           | 140 OUTSIDE   | 193 SWITCH        | 243 9              |
| 038 CIRCUIT      | 091 GATE          | 141 OVERFLOW  |                   | 244 9TH            |
| 039 CLIP         | 092 GLASS         | 142 OVERHEAD  | 194 TAMPER        |                    |
| 040 CLOSED       | 093 GUEST         |               | 195 TAPE          |                    |
| 041 COIN         | 094 GUN           | 143 PAINTING  | 196 TELCO         | 250 Custom Word #1 |
| 042 COLD         |                   | 144 PANIC     | 197 TELEPHONE     |                    |
| 043 COATROOM     | 095 HALL          | 145 PASSIVE   | 198 TELLER        |                    |
| 044 COLLECTION   | 096 HEAT          | 146 PATIO     | 199 TEMPERATURE   | 251 Custom Word #2 |
| 045 COMBUSTION   | 097 HIGH          | 147 PERIMETER | 200 THERMOSTAT    |                    |
| 046 COMPUTER     | 098 HOLDUP        | 148 PHONE     | 201 TOOL          |                    |
| 047 CONTACT      | 099 HOUSE         | 149 PHOTO     | 202 TRANSMITTER   | 252 Custom Word #3 |
|                  |                   | 150 POINT     | 203 TRAP          |                    |
| 048 DAUGHTERS    | 100 INFRARED      | 151 POLICE    |                   |                    |
| 049 DELAYED      | 101 INSIDE        | 152 POOL      | 204 ULTRA         | 253 Custom Word #4 |
| 050 DEN          | 102 INTERIOR      | 153 POWER     | 205 UP            |                    |
| 051 DESK         | 103 INTRUSION     |               | 206 UPPER         |                    |
| 052 DETECTOR     |                   | 154 QUAD      | 207 UPSTAIRS      | 254 Custom Word #5 |
| 053 DINING       | 104 JEWELRY       |               | 208 UTILITY       |                    |

## CHARACTER (ASCII) CHART

(For Adding Custom Words)

|            |      |      |      |      |      |
|------------|------|------|------|------|------|
| 32 (space) | 42 * | 52 4 | 62 > | 72 H | 82 R |
| 33 !       | 43 + | 53 5 | 63 ? | 73 I | 83 S |
| 34 "       | 44 , | 54 6 | 64 @ | 74 J | 84 T |
| 35 #       | 45 - | 55 7 | 65 A | 75 K | 85 U |
| 36 \$      | 46 . | 56 8 | 66 B | 76 L | 86 V |
| 37 %       | 47 / | 57 9 | 67 C | 77 M | 87 W |
| 38 &       | 48 0 | 58 : | 68 D | 78 N | 88 X |
| 39 '       | 49 1 | 59 ; | 69 E | 79 O | 89 Y |
| 40 (       | 50 2 | 60 < | 70 F | 80 P | 90 Z |
| 41 )       | 51 3 | 61 = | 71 G | 81 Q |      |

# Section 7. SYSTEM COMMUNICATION

## Report Code Formats

The Report Codes for Alarm, System Status, and Restore for Zones shown in fields \*56-\*75 above can be selected in field \*46 to report to the central station in any of the following formats:

The 3+1 and 4+1 Standard formats comprise a 3 (or 4) digit subscriber number and a single digit report code (e.g. Alarm, Trouble, Restore, Open, Close).

The 3+1 and 4+1 Expanded formats comprise a 3 (or 4) digit subscriber number, and a single digit report code, followed by a second line where the report code is repeated 3 (or 4) times and followed by another number (normally the zone number) or user ID related to that report.

The 4+2 formats comprise either a 4 digit subscriber number and two digit report code, or a 4 digit subscriber number and single digit report code, immediately followed by the zone number (normally) or user ID.

The Ademco Contact ID Reporting format comprises a 4 digit subscriber number, 1 digit event qualifier ("new" or "restore"), 3 digit event code, 2 digit "00", and 3 digit zone, contact ID, user, or system status number (see next page).

| Report              | 3+1/4+1<br>Standard   | 3+1/4+1<br>Expanded   | 4+2                                |
|---------------------|-----------------------|---|------------------------------------|
| Alarm               | SSS(S) A              | SSS(S) A<br>AAA(A) Z  | SSSS AZ                            |
| Trouble             | SSS(S) T              | SSS(S) T<br>TTT(T)t   | SSSS Tt                            |
| Bypass              | SSS(S) B              | SSS(S) B<br>BBB(B) b  | SSSS Bb                            |
| AC Loss             | SSS(S) E              | SSS(S) E<br>EEE(E) A <sub>C</sub>   | SSSS EA <sub>C</sub>               |
| Low Batt            | SSS(S) L              | SSS(S) L<br>LLL(L) L <sub>B</sub>   | SSSS LL <sub>B</sub>               |
| Open                | SSS(S) O              | SSS(S) O<br>OOO(O) U  | SSSS OU                            |
| Close               | SSS(S) C              | SSS(S) C<br>CCC(C) U  | SSSS CU                            |
| Test                | SSS(S) G              | SSS(S) G<br>GGG(G)g   | SSSS Gg                            |
| Restore             | SSS(S) R              | SSS(S) R<br>RRR(R) Z  | SSSS RZ                            |
| Alarm<br>AC Restore | SSS(S) R <sub>A</sub> | SSS(S) R <sub>A</sub><br>R <sub>A</sub> R <sub>A</sub> R <sub>A</sub> (R <sub>A</sub> )A <sub>C</sub> | SSSSR <sub>A</sub> A <sub>C</sub>  |
| LoBat Res.          | SSS(S) R <sub>L</sub> | SSS(S) R <sub>L</sub><br>R <sub>L</sub> R <sub>L</sub> R <sub>L</sub> (R <sub>L</sub> )L <sub>B</sub> | SSSS R <sub>L</sub> L <sub>B</sub> |
| Trouble Res.        | SSS(S) R <sub>T</sub> | SSS(S) R <sub>T</sub><br>R <sub>T</sub> R <sub>T</sub> R <sub>T</sub> (R <sub>T</sub> )t              | SSSS R <sub>T</sub> t              |
| Bypass Res.         | SSS(S) R <sub>B</sub> | SSS(S) R <sub>B</sub><br>R <sub>B</sub> R <sub>B</sub> R <sub>B</sub> (R <sub>B</sub> )b              | SSSS R <sub>B</sub> b              |

Where:

SSS or

SSSS = Subscriber ID

A = Alarm Code-1st digit

Z = Typically Zone Number\*-2nd digit

Tt = Trouble Code (1st & 2nd digits)

Bb = Bypass Code (1st & 2nd digits)

EA<sub>C</sub> = AC Loss Code (1st & 2nd digits)

LL<sub>B</sub> = Low Battery Code(1st & 2nd digits)

O = Open Code-1st Digit

C = Close Code-1st Digit

U = User Number (1st & 2nd digits)

Gg = Test Code (1st & 2nd digits)

R = Restore Code (Alarm)1st & 2nd digits

R<sub>T</sub>t = Restore Code (Trbl)1st & 2nd digits

R<sub>B</sub>b = Restore Code (Byps)1st & 2nd digits

R<sub>A</sub>A<sub>C</sub> = Restore Code (AC)1st & 2nd digits

R<sub>L</sub>L<sub>B</sub> = Restore Code (Bat)1st & 2nd digits

\*Zone numbers for: [\*] & [#] = 7      [1] + [\*] = 95

Duress = 8      [3] + [#] = 96

Tamper = 9

**Ademco Contact ID Reporting** takes the following format:

CCCC Q EEE GG ZZZ

where: CCCC = Customer (subscriber) ID

Q = Event qualifier, where:

E = new event, and R = restore

EEE = Event code (3 hexadecimal digits)

**Note:** For a complete list of event codes, refer to the central office receiver manual.

GG = Partition Number (system messages show 00)

ZZZ = Zone/contact ID number reporting the alarm, or user number for open/close reports. System status messages (AC Loss, Walk Test, etc.) contain zeroes in the ZZZ location.

## Section 8. REMOTE PROGRAMMING AND CONTROL (DOWNLOADING)

**General Information** The 4111XM can be remotely programmed from an IBM compatible Personal Computer (PC), a Hayes Modem, and Ademco's V-LINK® Software (as specified below).

Programming the control from a remote location is protected against compromise by someone attempting to defeat the system, using multi-levels of security protection:

1. **Security Code Handshake:** An 8-digit download ID code must be matched between the control and the downloader.
2. **Site Initiated Remote Programming:** The installer or subscriber initiates the callback from the subscriber premises (by pressing MASTER CODE + # + 1) while disarmed. All parameters can then be downloaded via the phone lines using a personal computer.
3. **Station Initiated Remote Programming:** The operator calls the site from your office to initiate the download call. The control hangs up and then calls back the PC via the preprogrammed telephone number. The unit can then be uploaded, downloaded, or controlled from your office.
4. **Data Encryption:** Data passed between the PC and the control is encrypted for security so that it is very difficult for a foreign device tapped into the phone line to take over communication and substitute system compromising information.

**Equipment Required** At the premises:

- 4111XM and console.

At the installer's office/home:

- An IBM PC compatible computer.
- *Either* a Hayes brand Smartmodem 1200 [Level 1.2 or higher external or Level 1.1 or higher (with 4 position DIP switch) internal style],  
or a Hayes brand Optima 24 Plus FAX96 Modem.
- A No. 4130PC Downloading Software Diskette (Rev. 2.2, or higher).
- Appropriate interconnecting cables.

**Programming** The downloading system can perform many functions when in communication with the control unit. Besides uploading and downloading, the status of the system can be observed and various commands can be initiated, as follows:

- Arm the System in the Away Mode; Disarm the System.
- Bypass a Zone.
- Force the System to Accept a New Program Download.
- Shut Down Communication (dialer) Functions (non-payment of monitoring fees in an owned system).
- Shut Down all Security System Functions (non-payment for a leased system).
- Inhibit Local Keypad Programming (prevents account takeover).
- Command the System to Upload a Copy of its Resident Program to the office.
- Read: Arming Status, AC Power Status, Lists of Faulted Zones, Bypassed Zones, Zones Currently in Alarm, Zones Currently in Trouble, and RF Sensors with Low Battery Conditions.



**Remote Programming  
Advisory Notes**

**Notes:** After the control and the PC have established valid communication, each console on the system will become inactive and will display "CC" or "MODEM COMM.". The control, however, will still be scanning its zones and looking for alarms. If an alarm does occur, after communication is broken off, alarms are sounded and the proper dialer reports are sent to the central station. The consoles will become active after the download communication is terminated. The detailed operation of the download functions is covered in the installation instructions for the 4130PC Downloading Software Diskette.

- Alarm and trouble reporting may be delayed during the time that the system and the Downloader are linked to each other following a valid exchange of codes, but the proper message will get through to the Central Station after the link is broken.
- Keypad entries are ignored during the time interval stated above.
- A copy of the program downloaded may be produced from the IBM PC compatible computer, using the product's internal report generator, when an optional printer is connected (consult your PC manual for proper printer and connections).
- Program Upload Time—One minute fifteen seconds for a complete program.
- Program Download Time—Depends on changes. Average time, one minute.

## Section 9. TESTING THE SYSTEM

**Procedure** After installation is completed, *each* partition of the Security System should be carefully tested.

1. With the System in the disarmed state, check that all zones are intact. If **NOT READY** is displayed, press the [\*] key to display the faulted zone(s). Restore faulted zone(s) if necessary, so that **READY** is displayed. Fault and restore every sensor individually to assure that it is being monitored by the system.
2. Enter the **security code** and press the **TEST** key. The outside sounder will sound for 1 second. The console should sound 3 beeps each time a contact is faulted. A test report should be transmitted (if programmed) to the Central Station immediately. If the backup battery is discharged or missing, the sounder may not turn on and a **LOW BATTERY** report will be transmitted with a **TEST** report. The console will beep once per minute as a reminder that the system is in the Test Mode. To turn off the test mode enter the **security code** and press the **OFF** key.

**Note:** For 5800 systems, triggering a zone set to Arm Away, Arm Stay, or Disarm will take the system out of **TEST** and cause that action.

**Alarm messages will be sent to the central station during the following tests 3 and 4. Notify them *in advance* that tests will be in progress.**

3. Arm the system and fault one or more zones. After 15 seconds (if optional dialer delay is selected), silence alarm sounder(s) by entering the **code** and pressing **OFF**. Check Entry/Exit delay zones.
4. Check the keypad-initiated alarms that are in the system by pressing the Panic key pairs. If the system has been programmed for audible emergency, the console will emit a steady alarm sound, and **ALARM and zone number** will be displayed. Silence the alarm by entering the **security code** and pressing **OFF**.

If the system has been programmed for silent emergency, there will be no audible alarms or displays, but a report will be sent to the central station.

5. If output Relay Units have been installed, test their programmed action.
6. Notify the central station when all tests are finished, and verify results with them.
7. To test the wireless part of the system and the RF Receiver, 3 additional test modes are available:
  - a. **HOUSE ID SNIFFER MODE** (*not applicable to, or necessary with, 5800 RF system*): By pressing **Installer code + # + 2**, a house code "sniffer" mode is enabled. The console will display the house code of any RF transmission it receives. In this way, you can check that you are not using the same house code as any nearby system (suggested test period: approx. 2 hrs). This mode can be exited by keying the **Installer code + OFF**.
  - b. **TRANSMITTER SNIFFER MODE**: Pressing **Installer code + # + 3** initiates a procedure to check that all transmitters have been properly programmed. The console will display all zone numbers of wireless units programmed into the system. As the system receives a signal from each of the transmitters, the zone number of that transmitter will disappear from the display. The transmitter codes may be checked upon installation, or in an installed system. All the wireless addresses should disappear after about 1-1/2 hours. This mode can be exited by keying **Installer code + OFF**. (**Note:** With a 5800 RF system, a transmitter not learned will not turn off its zone number.)
  - c. **GO/NO GO TEST MODE**: By pressing **Installer code + # + 4**, a mode similar to the user test mode (code + **TEST**) is entered, but the wireless receiver gain is reduced. Checking in this mode assists in determining good mounting locations for the transmitters when the system is being installed and verifies that the RF transmission has sufficient signal amplitude margin for the installed system. Exit the mode by entering **Installer code + OFF**.

**Note:** If the battery standby capacity is exceeded during an AC power failure, the control will automatically shut itself off.

## TROUBLESHOOTING GUIDE

| <b>S Y S T E M</b>   |  |   |
|--|--|---|
| <b>SYMPTOM</b>   | <b>POSSIBLE CAUSE</b>  | <b>REMEDY</b>   |
| <b>1. Transmitted signal not received at 4281/5881.</b>  | 1a. Transmitter or 4281/5881 not properly powered.<br>1b. Transmitter and 4281 not set to same house code.<br>1c. 5827 not being received by 5881.<br>1d. Transmitter located too far from 4281/5881.<br>1e. Metal shielding between transmitter and 4281/5881.<br>1f. Transmitter malfunctioning.<br>1g. 4281/5881 malfunctioning.<br>1h. Transmitter number (zone) not programmed.   | 1a. Check or change transmitter's battery. Check 4111XM's AC power.<br>1b. Check code switches inside transmitter. Must match with RF House Code programmed in 4111XM.<br>1c. House code for 5827 must be programmed into 4111XM.<br>1d. Move transmitter or 4281/5881.<br>1e. Check for large metal obstructions, then relocate transmitter if necessary.<br>1f. Verify by activating 4281/5881 with another, similar transmitter. If O.K. now, return defective transmitter.<br>1g. Verify by making sure other transmitters cannot activate 4281/5881. If defective, replace and return original 4281/5881.<br>1h. Verify programming. |
| <b>2. Transmitter zone number appears during Transmitter Sniffer mode, but does not clear.</b>   | 2a. Transmitter zone type (ZT) is set to 00 (Not Used).<br>2b. Transmitter battery not installed.<br>2c. 5700 System transmitter's DIP switch not set properly (house ID and transmitter ID).<br>2d. 5800 System transmitter not "learned" in system.<br>2e. With 5700 System, no response at all to any transmitter.  | 2a. Set ZT to a valid active zone type in field *56.<br>2b. Install proper battery.<br>2c. Check and set the DIP switch.<br>2d. "Learn" unit in field *56 or *83.<br>2e. Check 4281 receiver. It must be Rev. D or later and have "N5334Y1" marked on the large integrated circuit near the connector.  |
| <b>3. Low Battery message on console.</b>  | 3a. "Bat" alone.<br>3b. "Bat" + "00".<br>3c. "Bat" + "nn".   | 3a. System battery is low or missing.<br>3b. Remote RF keypad battery is low.<br>3c. Transmitter for zone nn has a low battery.   |
| <b>4. Periodic beep(s) from console.</b>   | 4a. System is in TEST mode.<br>4b. A transmitter low battery has occurred and is displayed.<br>4c. A supervision CHECK has occurred.   | 4a. Enter "Code" + OFF to exit TEST mode.<br>4b. Enter "Code" + OFF and replace the battery.<br>4c. Check the transmitter indicated. Restore communication to the receiver to cancel the condition.   |
| <b>5. With 5800 System, no response to a transmitter in normal operation, although zone number clears during Transmitter Sniffer mode.</b> | Put control in TEST mode. If zone does not respond, try operating the tamper switch or another input to the transmitter.<br>5a. If another input causes the zone to be displayed, the wrong input was "learned" when programming.<br>5b. If no response at all from this transmitter, this physical transmitter has not been learned by the system. Transmitter Sniffer display is being cleared by another unit programmed for this zone. | 5a. Delete input's serial number (not the zone), and learn the proper input (see field *56).<br>5b. Determine which transmitter is programmed for this zone and reprogram as necessary.   |
| <b>6. Nuisance or phantom alarm.</b>   | 6a. Sensors not properly installed, wired, or monitored.<br>6b. Nearby neighbor has 5700 system (4281) with same house code.<br>6c. Universal transmitter (5715/5817) programmed wrong.  | 6a. Check installation to see if in accordance with established procedure.<br>6b. Check with central monitoring station for neighbors with systems. Range can be 300 feet. Change house code if necessary.<br>6c. Check programming switches on transmitter.  |

(continued)

## TROUBLESHOOTING GUIDE (continued)

| <b>S Y S T E M (continued)</b>             |   |   |
|--|---|---|
| <b>SYMPTOM</b>                             | <b>POSSIBLE CAUSE</b>   | <b>REMEDY</b>   |
| 7. Intrusion alarm for no apparent reason. | 7a. Protected door or window opened while system armed.<br>7b. Improper user operation of exit/entry delays.<br>7c. Magnets located too far from switches, and/or doors and windows not properly aligned.<br>7d. Magnetic contacts improperly connected or wire broken.<br>7e. Entry door programmed as "instant".<br>7f. Loose fitting door or window being rattled by wind or vibrations. | 7a. Check with all occupants of protected home.<br>7b. Check setting of entry delay . Exit delay is 15 seconds longer than the entry delay time. Remind user of same.<br>7c. Check all openings for proper switch and magnet orientation.<br>7d. Check wiring connections. Be sure wires are properly stripped and tightly fastened to screw terminals.<br>7e. Check and revise program. Reprogram transmitter number.<br>7f. Mount magnet closer to contact. |
| 8. Repeated low battery signal.            | 8a. Transmitter located where temperature drops below 32° F.<br>8b. Poor quality or unspecified battery in transmitter.<br>8c. Transmitter malfunctioning.  | 8a. Change location. Use magnetic contacts to protect opening.<br>8b. Check battery. Use only 9V Duracell MN1604 or equivalent for 5700 System. Use only 3V lithium for 5800 System.<br>8c. Replace faulty transmitter.   |

| <b>C O N T R O L</b>                                |  |   |
|---|--|---|
| <b>SYMPTOM</b>                                      | <b>POSSIBLE CAUSE</b>  | <b>REMEDY</b>   |
| 1. "AC POWER" light off.                            | 1a. Interrupted AC power supply.   | 1a. Check transformer connection and power line circuit breaker.  |
| 2. Digital communicator message not being received. | 2a. 4111XM in TEST mode.<br>2b. Telephone connection not secure.<br>2c. Digital communicator malfunctioning.<br>2d. Telephone number in program needs prefix or access code.<br>2e. Telephone call to central monitoring station requires operator assistance. | 2a. Remove from TEST mode.<br>2b. Check all connections.<br>2c. Check with a different 4111XM.<br>2d. Program prefix or access code into 4111XM.<br>2e. 4111XM system cannot work in this situation.  |
| 3. Does not arm properly.                           | 3a. Ready light not on.  | 3a. Try Bypass arming.  |
| 4. 4111XM doesn't respond to keystrokes on console. | 4a. "CC" or "MODEM COMM" displayed.<br>4b. "d1" or "System Busy" displayed.<br>4c. "E4" or "E8" displayed.   | 4a. System is in communication with downloader at central station. Wait until download session is finished.<br>4b. System has just been powered and is in its one minute initialization. To bypass this time, press '#' + '0'.<br>4c. More zones have been programmed than the zone expansion modules can handle. Delete some zones or use a higher capability RF receiver. |

| <b>S M O K E D E T E C T O R</b>        |  |  |
|---|--|--|
| <b>SYMPTOM</b>                          | <b>POSSIBLE CAUSE</b>  | <b>REMEDY</b>  |
| 1. Detector alarms, no apparent reason. | 1a. Dust, dirt in sensing chamber.<br>1b. Improper location.<br>1c. Unit malfunctioning. | 1a. Clean unit's sensing chamber with vacuum cleaner per unit's instructions.<br>1b. See unit's instructions for locations to avoid. Relocate as necessary.<br>1c. Replace detector. |
| 2. Detector's siren sounds.             | 2a. Unit not receiving required power.<br>2b. Unit malfunctioning.                       | 2a. Check for proper installation of battery. Try new battery.<br>2b. Replace detector.  |

# Section 10. SPECIFICATIONS AND ACCESSORIES

## SPECIFICATIONS

### 4111XM SECURITY CONTROL

- 1. Physical:** 12-1/2" W x 14-1/2" H x 3" D  
(318mm x 368mm x 76mm)
- 2. Electrical:**  
VOLTAGE INPUT: 16.5VAC from plug-in 25VA transformer, Ademco No. 1321/TF2 (in U.S.A.)  
**Note:** For Canadian installations, a No. 1321CN transformer must be used.  
RECHARGEABLE BACK-UP BATTERY: 12VDC, 4AH (Gel type).  
Charging Voltage: 13.8VDC.  
ALARM SOUNDER: 12V, 2.0Amp output can drive 12V BELLS or can drive one or two 702 (**series** connected) self-contained 20-watt sirens. Do **not** connect two 702s in parallel.  
AUXILIARY POWER OUTPUT: 12VDC, 500mA max. Interrupts for smoke detector reset.  
**Note:** For UL installations, Alarm Sounder plus Auxiliary Power currents should not exceed 600mA total.  
STANDBY TIME: 5 HRS with Auxiliary load of 500mA (using 4AH battery). To determine total standby battery load, add 100mA to total Aux. power output and remote console currents.  
FUSES: Battery (3A) No. 90-12  
Sounder (2A) No. 90-2

### 3. Communication:

#### FORMATS SUPPORTED:

##### Ademco Express,

10 characters/sec, DTMF (TouchTone) Data Tones, 1400/2300Hz ACK, 1400Hz KISSOFF.

##### Ademco Contact ID Reporting,

10 characters/sec., DTMF (TouchTone) Data Tones, 1400/2300Hz ACK, 1400Hz KISSOFF.

**Ademco Low Speed,** 10 pulses/sec, 1900Hz Data Tone, 1400Hz ACK/KISSOFF.

**Radionics/SESCOA,** 20 pulses/sec, 1800Hz Data Tone, 2300Hz ACK/KISSOFF.

Can report 0-9, B-F

Line Seize: Double Pole

Ringer Equivalence: 0.7B

FCC Registration No.: AC 398U-68192-AL-E

### 4127 REMOTE CONSOLE

- 1. Physical:** 5-5/8" W x 4-11/16" H x 7/8" D  
(143mm x 119mm x 22mm)
- 2. Electrical:** Voltage Input: 12VDC  
Current Drain: 20mA
- 3. Interface Wiring:**  
RED: 12VDC input (+) aux pwr  
GREEN: Data Out to Control  
YELLOW: Data In from Control  
BLACK: Ground

### 4137 & 5137 REMOTE CONSOLES

- 1. Physical:** 8-2/5" W x 4-3/4" H x 1-1/10" D  
(213mm x 121mm x 28mm)
- 2. Electrical:** Voltage Input: 12VDC  
Current Drain: 60mA (4137)  
90mA (5137)

- 4281L, 4281M, 4281H  
RF RECEIVERS  
(5700 System)  
and  
5881L, 5881M, 5881H  
RF RECEIVERS  
(5800 System)**
- 3. Interface Wiring:**  
 RED: 12VDC input (+) aux pwr  
 BLUE: 18VDC input from optional  
 No 1350 or 1360 Power Pack  
 (not usable for UL installations)  
 GREEN: Data Out to Control  
 YELLOW: Data In from Control  
 BLACK: Ground and (-) connection from  
 optional No. 1350 or 1360 Power Pack
- 1. Physical:** 7-3/8" (188mm)W  
 4-3/8" (112mm) H  
 10-7/8" (277mm) H ←with antenna  
 1-7/16" (37mm) D
- 2. Electrical:** Voltage Input: 12VDC  
 (from control's remote console connection points)  
 Current Drain: 35mA
- 3. Interface Wiring:**  
 RED: 12VDC input (+) aux pwr  
 GREEN: Data Out to Control  
 YELLOW: Data In from Control  
 BLACK: Ground
- 4. Range:** 200ft (60m) nominal indoors from wireless transmitters (the actual range to be determined with system in TEST mode).
- 5. Zones:** With the 4111XM:  
4281L: accepts up to 4 transmitters  
4281M/5881L: accepts up to 8 transmitters  
5881M: accepts up to 16 transmitters  
4281H/5881H: accepts up to 22 transmitters
- 4219  
WIRED EXPANSION  
UNIT**
- 1. Physical:** 6-1/2" W x 4-1/4" H x 1-1/4" D  
 (169mm x 108mm x 32mm)
- 2. Electrical:** Voltage Input: 12VDC  
 (from control's remote console connection points)  
 Current Drain: 35mA
- 3. Interface Wiring:**  
 RED: 12VDC input (+) aux pwr  
 GREEN: Data Out to Control  
 YELLOW: Data In from Control  
 BLACK: Ground
- 4. 8 EOLR Loops (A-H):** Loop A can be set for fast (10-15msec) response to an open.
- 4204  
RELAY UNIT**
- 1. Physical:** 6-1/2" W x 4-1/4" H x 1-1/4" D  
 (169mm x 108mm x 32mm)
- 2. Electrical:** Voltage Input: 12VDC  
 (from control's remote console connection points)  
 Current Drain: 15mA (Relays off)  
 180mA (Relays on)
- 3. Interface Wiring:**  
 RED: 12VDC input (+) aux pwr  
 GREEN: Data Out to Control  
 YELLOW: Data In from Control  
 BLACK: Ground
- 4. Four Output Relays:** SPDT Contacts,  
 Rating: 2A max at 28VDC/AC  
 (120VAC for non-UL installations)

**4229  
WIRED EXPANSION/  
RELAY UNIT**

1. **Physical:** 6-1/2" W x 4-1/4" H x 1-1/4" D  
(169mm x 108mm x 32mm)
2. **Electrical:** Voltage Input: 12VDC  
(from control's remote console connection points)  
Current Drain: 35mA (Relays off)  
100mA (Relays on)
3. **Interface Wiring:**  
RED: 12VDC input (+) aux pwr  
GREEN: Data Out to Control  
YELLOW: Data In from Control  
BLACK: Ground
4. **8 EOLR Loops (A-H):** Loop A can be set for fast (10-15msec) response to an open.
5. **Two Output Relays:** SPDT Contacts,  
Rating: 2A max at 28VDC/AC  
(120VAC for non-UL installations)

**ACCESSORIES (COMPATIBLE DEVICES)**

- Accessories**
- No. 1321/TF2 16.5VAC, 25VA Plug-In Transformer (in U.S.A.)
  - No. 1321CN 16.5VAC, 25VA Plug-in Transformer (in Canada)
  - No. 702 Self-contained 20 watt Siren (indoor or outdoor).
  - No. 740 Extremely loud Piezoelectric Alarm Sounder, 122dB output (indoor or outdoor).
  - No. 5716BR Brown Cases and Mounting Brackets (3) for 5716, 5716WM.
  - No. 5799 Pkg. of 8 Magnets for 5716
- System Sensor:**
- PA400B Piezoelectric Alarm Sounder, 90dB output (mounts in single-gang box).
  - 1412 4-wire Ionization Products of Combustion Detector
  - 2412 4-wire Photoelectric Smoke Detector
  - 2412TH 4-wire Photoelectric Smoke Detector w/135°F (57°C) Heat Detector

**5700 RF System  
Wireless Transmitters  
for  
4281**

**5701 Panic Transmitter**

Programmable for either silent or audible 24 hour alarm (can be DIP switch programmed for zones 62 or 63).

**5706 & 5707 Wireless Photoelectric Smoke Detectors**

One piece smoke detectors with built-in transmitter (DIP switch programmable for zones 48-55). Built-in UL Listed 85 dB piezoelectric alarm sounder and audible low battery warning.

**5711 Slimline Door/Window Transmitter**

Can be used with any closed circuit sensor.

**5711WM Slimline Door/Window Transmitter  
w/Reed Switch**

Magnet included for built-in reed switch. Can also be used with any closed circuit sensor.

**5715WH (White) or 5715BR (Brown)  
Universal Transmitter**

DIP switch selectable for fast response, open or closed sensor usage, and has a tamper protected cover. Use in applications where open circuit heat detectors are needed or where fast response devices are employed.

**5716 Small Door/Window Transmitter  
5716WM Small Door/Window Xmtr w/Magnet**

Can be used with any open or closed circuit sensor (DIP switch selectable). Features a built-in reed switch.

#### **5742 Audio Discriminator/Transmitter**

For use in unoccupied areas to detect the sound of shattering glass when a window is broken. Built-in 5716 type transmitter.

#### **5743 Dual Technology Glass Break Detector/Transmitter**

Detects the sound *and* shock vibrations of breaking glass and requires the presence of *both* to initiate an alarm condition transmission. Built-in 5716 type transmitter.

#### **5775 PIR Detector/Transmitter**

Dual element passive infrared detector/transmitter with built-in selectable pulse count. DIP switch programmable for zones 32-47. *Note:* There is a 3 minute lock-out between transmissions to conserve battery life.

#### **5727 Wireless Keypad**

Can be used to turn the burglary protection on and off, and features the same built-in panic functions as wired consoles for either silent or audible 24 hour alarm. An LED indication lights each time a key is pressed, to verify transmission. The keypad is identified (as zone "00" on fixed English consoles) when it transmits with a low battery .

#### **5800 RF System Wireless Transmitters for 5881**

#### **5801 Wireless Panic Transmitter**

Has four pushbuttons, each with a unique input code. The control unit's response to each of the buttons is programmable (e.g., Panic, Arm-Stay, Arm-Away, Disarm, etc. *See note below 5803.*

#### **5802 Pendant & 5802CP Belt Clip (Personal Emergency) Transmitters**

Their single pushbuttons should usually be programmed for control unit response of 24 Hr Audible or 24 Hr Silent. Other zone responses are possible. Each contains a non-replaceable battery. At end of its life, the entire unit should be replaced. *See note below 5803.*

#### **5803 Wireless Key Transmitter**

Has three pushbuttons, each with a unique input code. The control unit's response to each of the buttons is programmable (e.g., Arm-Stay, Arm-Away, Disarm, etc.). Contains a non-replaceable battery. At end of its life, the entire unit should be replaced.

**Note:** The 5801, 5802, 5802CP, and 5803 should usually be programmed as unsupervised (no periodic check-in signal) so that they may be carried off-premises: UR" (unsupervised RF) type for 5801, "BR" (button RF) type for 5802, 5802CP, and 5803. See each unit's instructions for complete information.

#### **5806 & 5807 Wireless Photoelectric Smoke Detectors**

One piece smoke detectors with built-in transmitter. Built-in UL Listed 85 dB piezoelectric alarm sounder and audible low battery warning. Should be learned as "RF" (supervised RF) type.

#### **5816 Door/Window Transmitter**

Has two unique input codes: one for a wired closed circuit contact loop, and the other for a built-in reed switch (used in conjunction with a magnet). Should be learned as "RF" (supervised RF) type.

#### **5817 Multi-Point Universal Transmitter**

Has three unique input codes: one for a DIP switch settable "Primary" contact loop, and the others for two "Auxiliary" closed circuit contact loops. The "Primary" loop may be set for: a) Repeating or Single Transmission, b) Normally Open or Normally Closed Circuit, c) Slow or Fast Response, and d) 3 Minute or No Transmission Inhibit. Should be learned as "RF" (supervised RF) type.

#### **5827 Wireless Keypad**

Can be used to turn the burglary protection on and off, and features the same built-in panic functions as wired consoles for either silent or audible 24 hour alarm. An LED indication lights each time a key is pressed, to verify transmission. The keypad is identified (as zone "00" on fixed English consoles) when it transmits with a low battery .



#### **5849 Glass Break Detector/Transmitter**

When sound and shock of breaking glass are detected by this unit at the same time, a wireless alarm will be transmitted via the unit's unique identification code. Separate alarm and cover tamper signals permit 24 hour monitoring. Should be learned as "RF" (supervised RF) type.

#### **5890 PIR Detector/Transmitter**

Has unique input code for its dual element passive infrared detector/transmitter with built-in selectable pulse count. **Note:** There is a 3 minute lock-out between transmissions to conserve battery life. Should be learned as "RF" (supervised RF) type.

#### **TO THE INSTALLER**

Regular maintenance and inspection (at least annually) by the installer and frequent testing by the user are vital to continuous satisfactory operation of any alarm system.

The installer should assume the responsibility of developing and offering a regular maintenance program to the user as well as acquainting the user with the proper operation and limitations of the alarm system and its component parts. Recommendations must be included for a specific program of frequent testing (at least weekly) to insure the system's proper operation at all times.

| <b>OUTPUT RELAY EXAMPLES TABLE</b>  |              |       |    |    |   |      |    |   |
|---|--------------|-------|----|----|---|------|----|---|
| ACTION DESIRED  | RELAY ACTION | START |    |    |   | STOP |    |   |
|   | A            | EV    | ZL | ZT | P | ZL   | ZT | P |
| Zones in zone list (x) close relay for 2 seconds on alarms.   | 1            | 1     | x  | 00 | 0 | 0    | 00 | 0 |
| Zones in zone list (x) close relay for 2 seconds on troubles.   | 1            | 3     | x  | 00 | 0 | 0    | 00 | 0 |
| Zones in zone list (x) close relay for 2 seconds on faults*.  | 1            | 2     | x  | 00 | 0 | 0    | 00 | 0 |
| <i>*Will activate relay for any zone type plus panics on 5801 whether control is armed or disarmed. (Console panics will not activate a relay with the configurations above.)</i> |              |       |    |    |   |      |    |   |
| Zones in zone list (x) close relay on alarms and reset at bell timeout or when disarmed by any partition.   | 2            | 1     | x  | 00 | 0 | 0    | 36 | 0 |
| Zones in zone list (x) pulse relay on alarms and reset at bell timeout or when disarmed by any partition.   | 3            | 1     | x  | 00 | 0 | 0    | 36 | 0 |
| Zones in zone list (x) close relay on alarms and reset when zone is restored.*  | 2            | 1     | x  | 00 | 0 | x    | 00 | 0 |
| Zones in zone list (x) pulse relay on alarms and reset when zone is restored.*  | 3            | 1     | x  | 00 | 0 | x    | 00 | 0 |
| <i>*Console panics will not activate a relay with these configurations. The relay can also be activated by troubles or faults by changing the EV (event) accordingly.</i>         |              |       |    |    |   |      |    |   |
| Zones in zone list (x) close relay on alarms and reset when disarmed by any partition. (Latching relay for strobes.)*   | 2            | 1     | x  | 00 | 0 | 0    | 22 | 0 |
| Zones in zone list (x) pulse a relay on alarms and reset when disarmed by any partition.*   | 3            | 1     | x  | 00 | 0 | 0    | 22 | 0 |
| <i>*Relay will activate for burglary, fire, and panic alarms if programmed into zone list.</i>  |              |       |    |    |   |      |    |   |
| Close relay after any burglary alarm and reset when disarmed by any partition.*   | 2            | 0     | 0  | 33 | 0 | 0    | 22 | 0 |
| Close relay after any burglary alarm and reset at bell timeout or when disarmed by any partition.*  | 2            | 0     | 0  | 33 | 0 | 0    | 36 | 0 |
| <i>*Response types 06,08, and 09 will not activate relay. If PULSE relay is desired, enter a 3 in A (action).</i>   |              |       |    |    |   |      |    |   |
| Close relay when ARMED-AWAY by Partition 1, reset when DISARMED by Partition 1.*  | 2            | 0     | 0  | 21 | 1 | 0    | 22 | 1 |
| Close relay when ARMED-STAY by Partition 2, reset when DISARMED by Partition 2.*  | 2            | 0     | 0  | 20 | 2 | 0    | 22 | 2 |
| <i>*If PULSED relay is desired, enter a 3 in A (action).</i>  |              |       |    |    |   |      |    |   |
| Close relay for 2 seconds at end of exit delay time after system is armed by any partition (confirmation ding).   | 1            | 0     | 0  | 31 | 0 | 0    | 00 | 0 |
| Pulse relay at start of entry time of Partition 1 and reset when system is disarmed by Partition 1 (entry warning).   | 3            | 0     | 0  | 32 | 1 | 0    | 22 | 1 |
| Close relay for 2 seconds during chime at Partition 2. (Chime mode must be turned on at Partition 2's control.)   | 1            | 0     | 0  | 38 | 2 | 0    | 00 | 0 |

(continued)

### OUTPUT RELAY EXAMPLES TABLE

| ACTION DESIRED   | RELAY ACTION | START |    |    |   | STOP |    |   |
|--|--------------|-------|----|----|---|------|----|---|
|  | A            | EV    | ZL | ZT | P | ZL   | ZT | P |
| Close relay at start of entry time of Partition 2 and reset with key entry of security code + # + 7 by Partition 2.*                               | 2            | 0     | 0  | 32 | 2 | 0    | 34 | 2 |
| <i>*Can be used to turn on a light when entry door is opened.</i>  |              |       |    |    |   |      |    |   |
| Close relay after any burglary alarm and reset with key entry of security code + # + 8 by any partition.*  | 2            | 0     | 0  | 33 | 0 | 0    | 35 | 0 |
| <i>*Can be used to turn on lights in the event of a burglary alarm...(NOTE: Response types 06, 08, and 09 will not activate relay).</i>            |              |       |    |    |   |      |    |   |
| Zones in zone list (x) close relay on alarms and reset with key entry of security code + # + 7 by any partition. (Possible use with strobe light.) | 2            | 1     | x  | 00 | 0 | 0    | 34 | 0 |
| Zones in zone list (x) pulse relay on alarms and reset with key entry of security code + # + 7 by any partition.                                   | 3            | 1     | x  | 00 | 0 | 0    | 34 | 0 |
| A system low battery detection causes relay to close for 2 seconds.*   | 1            | 0     | 0  | 42 | 0 | 0    | 00 | 0 |
| An AC loss detection causes relay to close for 2 seconds.*   | 1            | 0     | 0  | 41 | 0 | 0    | 00 | 0 |
| <i>*The relay will not reset on restoral of low battery or AC power. For this reason, using "close for 2 seconds" in A(action) is recommended.</i> |              |       |    |    |   |      |    |   |
| Bypassing a zone by Partition 1 will cause relay to close for 2 seconds.   | 1            | 0     | 0  | 40 | 1 | 0    | 00 | 0 |
| Bypassing a zone by Partition 2 causes relay to close and will reset with a disarm sequence (code + off) by Partition 2.                           | 2            | 0     | 0  | 40 | 2 | 0    | 22 | 2 |
| Any FIRE alarm causes relay to pulse on and off and will reset with an entry of a disarm sequence (code + off) by any partition.                   | 3            | 0     | 0  | 39 | 0 | 0    | 22 | 0 |
| An alarm or trouble condition on any FIRE zone causes relay to close and will reset when condition clears.   | 1            | 0     | 0  | 09 | 0 | 0    | 09 | 0 |

## DIP SWITCH TABLES FOR 5700 RF SYSTEM WIRELESS DEVICES

### House ID Switch Setting for All Devices Except 5716

| HOUSE ID   | DIP SWITCH SETTINGS |    |    |    |    |
|------------|---------------------|----|----|----|----|
|            | 1                   | 2  | 3  | 4  | 5  |
| 1          | UP                  | UP | UP | UP | dn |
| 2          | UP                  | UP | UP | dn | UP |
| 3          | UP                  | UP | UP | dn | dn |
| 4          | UP                  | UP | dn | UP | UP |
| 5          | UP                  | UP | dn | UP | dn |
| 6          | UP                  | UP | dn | dn | UP |
| 7          | UP                  | UP | dn | dn | dn |
| 8          | UP                  | dn | UP | UP | UP |
| 9          | UP                  | dn | UP | UP | dn |
| 10         | UP                  | dn | UP | dn | UP |
| 11         | UP                  | dn | UP | dn | dn |
| 12         | UP                  | dn | dn | UP | UP |
| 13         | UP                  | dn | dn | UP | dn |
| 14         | UP                  | dn | dn | dn | UP |
| 15         | UP                  | dn | dn | dn | dn |
| 16         | dn                  | UP | UP | UP | UP |
| 17         | dn                  | UP | UP | UP | dn |
| 18         | dn                  | UP | UP | dn | UP |
| 19         | dn                  | UP | UP | dn | dn |
| 20         | dn                  | UP | dn | UP | UP |
| 21         | dn                  | UP | dn | UP | dn |
| 22         | dn                  | UP | dn | dn | UP |
| 23         | dn                  | UP | dn | dn | dn |
| 24         | dn                  | dn | UP | UP | UP |
| 25         | dn                  | dn | UP | UP | dn |
| 26         | dn                  | dn | UP | dn | UP |
| 27         | dn                  | dn | UP | dn | dn |
| 28         | dn                  | dn | dn | UP | UP |
| 29         | dn                  | dn | dn | UP | dn |
| 30         | dn                  | dn | dn | dn | UP |
| 31         | dn                  | dn | dn | dn | dn |
| BIT VALUE: | 16                  | 8  | 4  | 2  | 1  |

### 5701 Panic Xmtr.

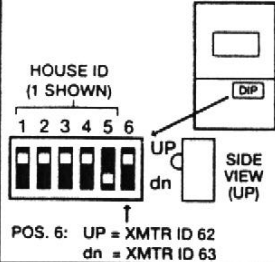

### 5727 Keypad

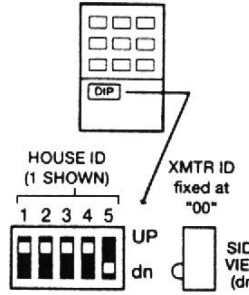

### 5706/5707 Smoke Detector Transmitter

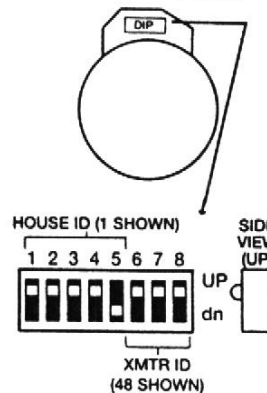

| XMTR ID | DIP SWITCH SETTINGS |    |    |
|---------|---------------------|----|----|
|         | 6                   | 7  | 8  |
| 48      | UP                  | UP | UP |
| 49      | UP                  | UP | dn |
| 50      | UP                  | dn | UP |
| 51      | UP                  | dn | dn |
| 52      | dn                  | UP | UP |
| 53      | dn                  | UP | dn |
| 54      | dn                  | dn | UP |
| 55      | dn                  | dn | dn |

### 5775 PIR Detector/Transmitter

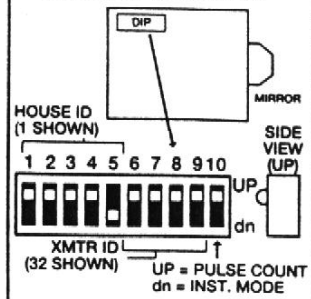

| XMTR ID | DIP SWITCH SETTINGS |    |    |    |
|---------|---------------------|----|----|----|
|         | 6                   | 7  | 8  | 9  |
| 32      | UP                  | UP | UP | UP |
| 33      | UP                  | UP | UP | dn |
| 34      | UP                  | UP | dn | UP |
| 35      | UP                  | UP | dn | dn |
| 36      | UP                  | dn | UP | UP |
| 37      | UP                  | dn | UP | dn |
| 38      | UP                  | dn | dn | UP |
| 39      | UP                  | dn | dn | dn |
| 40      | dn                  | UP | UP | UP |
| 41      | dn                  | UP | UP | dn |
| 42      | dn                  | UP | dn | UP |
| 43      | dn                  | UP | dn | dn |
| 44      | dn                  | dn | UP | UP |
| 45      | dn                  | dn | UP | dn |
| 46      | dn                  | dn | dn | UP |
| 47      | dn                  | dn | dn | dn |

### 5715 Universal Xmtr.

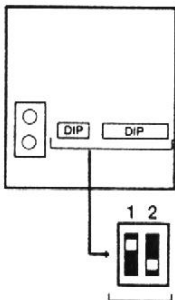

POS. 1: UP = NORMAL RESPONSE  
dn = FAST RESPONSE  
POS. 2: UP = NO COVER TAMPER  
dn = COVER TAMPER (use N.C. setting)

| XMTR ID    | DIP SWITCH SETTINGS |    |    |    |    |    |
|------------|---------------------|----|----|----|----|----|
|            | 6                   | 7  | 8  | 9  | 10 | 11 |
| 1          | UP                  | UP | UP | UP | UP | dn |
| 2          | UP                  | UP | UP | UP | dn | UP |
| 3          | UP                  | UP | UP | dn | UP | UP |
| 4          | UP                  | UP | UP | dn | UP | dn |
| 5          | UP                  | UP | dn | UP | UP | UP |
| 6          | UP                  | UP | dn | UP | UP | dn |
| 7          | UP                  | UP | dn | dn | UP | UP |
| 8          | UP                  | UP | dn | dn | UP | dn |
| 9          | UP                  | UP | dn | dn | dn | UP |
| 10         | UP                  | UP | dn | dn | dn | dn |
| 11         | UP                  | dn | UP | UP | UP | UP |
| 12         | UP                  | dn | UP | UP | UP | dn |
| 13         | UP                  | dn | UP | dn | UP | UP |
| 14         | UP                  | dn | UP | dn | UP | dn |
| 15         | UP                  | dn | UP | dn | dn | UP |
| 16         | UP                  | dn | UP | dn | dn | dn |
| 17         | UP                  | dn | dn | UP | UP | UP |
| 18         | UP                  | dn | dn | UP | UP | dn |
| 19         | UP                  | dn | dn | UP | dn | UP |
| 20         | UP                  | dn | dn | UP | dn | dn |
| 21         | UP                  | dn | dn | dn | UP | UP |
| 22         | UP                  | dn | dn | dn | UP | dn |
| 23         | UP                  | dn | dn | dn | dn | UP |
| 24         | UP                  | dn | dn | dn | dn | dn |
| 25         | dn                  | UP | UP | UP | UP | UP |
| 26         | dn                  | UP | UP | UP | UP | dn |
| 27         | dn                  | UP | UP | dn | UP | UP |
| 28         | dn                  | UP | UP | dn | UP | dn |
| 29         | dn                  | UP | UP | dn | dn | UP |
| 30         | dn                  | UP | UP | dn | dn | dn |
| 31         | dn                  | UP | UP | dn | dn | dn |
| 32         | dn                  | UP | UP | UP | UP | UP |
| BIT VALUE: | 32                  | 16 | 8  | 4  | 2  | 1  |

### 5711/5711WM Door/Window Transmitter

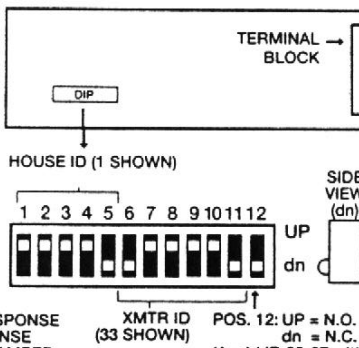

| XMTR ID    | DIP SWITCH SETTINGS |    |    |    |    |    |
|------------|---------------------|----|----|----|----|----|
|            | 6                   | 7  | 8  | 9  | 10 | 11 |
| 33         | dn                  | UP | UP | UP | UP | dn |
| 34         | dn                  | UP | UP | UP | dn | UP |
| 35         | dn                  | UP | UP | UP | dn | dn |
| 36         | dn                  | UP | UP | dn | UP | UP |
| 37         | dn                  | UP | UP | dn | UP | dn |
| 38         | dn                  | UP | UP | dn | dn | UP |
| 39         | dn                  | UP | UP | dn | dn | dn |
| 40         | dn                  | UP | dn | UP | UP | UP |
| 41         | dn                  | UP | dn | UP | UP | dn |
| 42         | dn                  | UP | dn | UP | dn | UP |
| 43         | dn                  | UP | dn | UP | dn | dn |
| 44         | dn                  | UP | dn | dn | UP | UP |
| 45         | dn                  | UP | dn | dn | UP | dn |
| 46         | dn                  | UP | dn | dn | dn | UP |
| 47         | dn                  | UP | dn | dn | dn | dn |
| 48         | dn                  | dn | UP | UP | UP | UP |
| 49         | dn                  | dn | UP | UP | UP | dn |
| 50         | dn                  | dn | UP | UP | dn | UP |
| 51         | dn                  | dn | UP | UP | dn | dn |
| 52         | dn                  | dn | UP | dn | UP | UP |
| 53         | dn                  | dn | UP | dn | UP | dn |
| 54         | dn                  | dn | UP | dn | dn | UP |
| 55         | dn                  | dn | UP | dn | dn | dn |
| 56         | dn                  | dn | dn | UP | UP | UP |
| 57         | dn                  | dn | dn | UP | UP | dn |
| 58         | dn                  | dn | dn | UP | dn | UP |
| 59         | dn                  | dn | dn | UP | dn | dn |
| 60         | dn                  | dn | dn | dn | UP | UP |
| 61         | dn                  | dn | dn | dn | UP | dn |
| 62         | dn                  | dn | dn | dn | dn | UP |
| 63         | dn                  | dn | dn | dn | dn | dn |
| BIT VALUE: | 32                  | 16 | 8  | 4  | 2  | 1  |

### 5716 Door/Window Transmitter

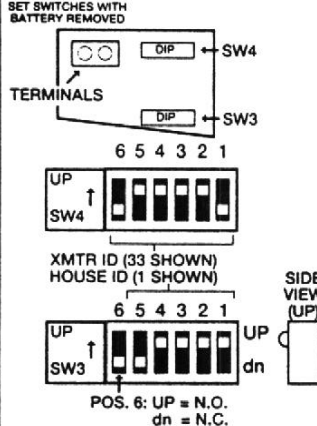

| HOUSE ID   | DIP SWITCH SETTINGS |    |    |    |    |
|------------|---------------------|----|----|----|----|
|            | 5                   | 4  | 3  | 2  | 1  |
| 1          | dn                  | UP | UP | UP | UP |
| 2          | UP                  | dn | UP | UP | UP |
| 3          | dn                  | dn | UP | UP | UP |
| 4          | UP                  | UP | dn | UP | UP |
| 5          | dn                  | UP | dn | UP | UP |
| 6          | UP                  | dn | dn | UP | UP |
| 7          | dn                  | dn | dn | UP | UP |
| 8          | UP                  | UP | UP | dn | UP |
| 9          | dn                  | UP | UP | dn | UP |
| 10         | UP                  | dn | UP | dn | UP |
| 11         | dn                  | dn | UP | dn | UP |
| 12         | UP                  | UP | dn | dn | UP |
| 13         | dn                  | UP | dn | dn | UP |
| 14         | UP                  | dn | dn | dn | UP |
| 15         | dn                  | dn | dn | dn | UP |
| 16         | UP                  | UP | UP | UP | dn |
| 17         | dn                  | UP | UP | UP | dn |
| 18         | UP                  | dn | UP | UP | dn |
| 19         | dn                  | dn | UP | UP | dn |
| 20         | UP                  | UP | dn | UP | dn |
| 21         | dn                  | UP | dn | UP | dn |
| 22         | UP                  | dn | dn | UP | dn |
| 23         | dn                  | dn | dn | UP | dn |
| 24         | UP                  | UP | UP | UP | dn |
| 25         | dn                  | UP | UP | UP | dn |
| 26         | UP                  | dn | UP | UP | dn |
| 27         | dn                  | dn | UP | UP | dn |
| 28         | UP                  | UP | dn | dn | dn |
| 29         | dn                  | UP | dn | dn | dn |
| 30         | UP                  | dn | dn | dn | dn |
| 31         | dn                  | dn | dn | dn | dn |
| BIT VALUE: | 1                   | 2  | 4  | 8  | 16 |

| TRANSMITTER ID | DIP SWITCH SETTINGS |    |    |    |    |    |
|----------------|---------------------|----|----|----|----|----|
|                | 6                   | 5  | 4  | 3  | 2  | 1  |
| 1              | dn                  | UP | UP | UP | UP | UP |
| 2              | UP                  | dn | UP | UP | UP | UP |
| 3              | dn                  | dn | UP | UP | UP | UP |
| 4              | UP                  | UP | dn | UP | UP | UP |
| 5              | dn                  | UP | dn | UP | UP | UP |
| 6              | UP                  | dn | dn | UP | UP | UP |
| 7              | dn                  | UP | dn | dn | UP | UP |
| 8              | UP                  | UP | UP | dn | UP | UP |
| 9              | dn                  | UP | UP | dn | UP | UP |
| 10             | UP                  | dn | UP | dn | UP | UP |
| 11             | dn                  | dn | UP | dn | UP | UP |
| 12             | UP                  | UP | dn | dn | UP | UP |
| 13             | dn                  | UP | dn | dn | UP | UP |
| 14             | UP                  | UP | dn | dn | UP | UP |
| 15             | dn                  | dn | dn | dn | UP | UP |
| 16             | UP                  | UP | UP | UP | dn | UP |
| 17             | dn                  | UP | UP | UP | dn | UP |
| 18             | UP                  | dn | UP | UP | dn | UP |
| 19             | dn                  | dn | UP | UP | dn | UP |
| 20             | UP                  | UP | dn | UP | dn | UP |
| 21             | dn                  | UP | dn | UP | dn | UP |
| 22             | UP                  | dn | dn | UP | dn | UP |
| 23             | dn                  | dn | UP | UP | dn | UP |
| 24             | UP                  | UP | UP | UP | dn | UP |
| 25             | dn                  | UP | UP | UP | dn | UP |
| 26             | UP                  | dn | UP | UP | dn | UP |
| 27             | dn                  | dn | UP | UP | dn | UP |
| 28             | UP                  | UP | UP | UP | dn | UP |
| 29             | dn                  | UP | UP | UP | dn | UP |
| 30             | UP                  | dn | UP | UP | dn | UP |
| 31             | dn                  | dn | UP | UP | dn | UP |
| 32             | UP                  | UP | UP | UP | UP | UP |
| 33             | dn                  | UP | UP | UP | UP | UP |
| 34             | UP                  | dn | UP | UP | UP | UP |
| 35             | dn                  | dn | UP | UP | UP | UP |
| 36             | UP                  | UP | dn | UP | UP | UP |
| 37             | dn                  | UP | dn | UP | UP | UP |
| 38             | UP                  | dn | dn | UP | UP | UP |
| 39             | dn                  | dn | dn | UP | UP | UP |
| 40             | UP                  | UP | UP | dn | UP | UP |
| 41             | dn                  | UP | UP | dn | UP | UP |
| 42             | UP                  | dn | UP | dn | UP | UP |
| 43             | dn                  | UP | UP | dn | UP | UP |
| 44             | UP                  | UP | dn | dn | UP | UP |
| 45             | UP                  | UP | dn | dn | UP | UP |
| 46             | UP                  | dn | dn | dn | UP | UP |
| 47             | dn                  | dn | dn | dn | UP | UP |
| 48             | UP                  | UP | UP | UP | dn | UP |
| 49             | dn                  | UP | UP | UP | dn | UP |
| 50             | UP                  | dn | UP | UP | dn | UP |
| 51             | dn                  | dn | UP | UP | dn | UP |
| 52             | UP                  | UP | dn | UP | dn | UP |
| 53             | dn                  | UP | dn | UP | dn | UP |
| 54             | UP                  | dn | dn | UP | dn | UP |
| 55             | dn                  | dn | dn | UP | dn | UP |
| 56             | UP                  | UP | UP | UP | dn | UP |
| 57             | dn                  | UP | UP | UP | dn | UP |
| 58             | UP                  | UP | UP | UP | dn | UP |
| 59             | dn                  | UP | UP | UP | dn | UP |
| 60             | UP                  | UP | UP | UP | dn | UP |
| 61             | dn                  | UP | UP | UP | dn | UP |
| 62             | UP                  | dn | UP | UP | dn | UP |
| 63             | dn                  | dn | dn | dn | dn | UP |
| BIT VALUE:     | 1                   | 2  | 4  | 8  | 16 | 32 |

**Note:** For a 5827 (5800 System) Wireless Keypad, House ID settings are opposite to those for a 5727 (i.e., "UP" is "dn" and "dn" is "UP").



## **UL NOTICE: This is a "Grade A" residential system.**

### **FEDERAL COMMUNICATIONS COMMISSION (FCC) Part 15 STATEMENT**

This equipment has been tested to FCC requirements and has been found acceptable for use. The FCC requires the following statement for your information:

This equipment generates and uses radio frequency energy and if not installed and used properly, that is, in strict accordance with the manufacturer's instructions, may cause interference to radio and television reception. It has been type tested and found to comply with the limits for a Class B computing device in accordance with the specifications in Part 15 of FCC Rules, which are designed to provide reasonable protection against such interference in a residential installation. However, there is no guarantee that interference will not occur in a particular installation. If this equipment does cause interference to radio or television reception, which can be determined by turning the equipment off and on, the user is encouraged to try to correct the interference by one or more of the following measures:

- If using an indoor antenna, have a quality outdoor antenna installed.
- Reorient the receiving antenna until interference is reduced or eliminated.
- Move the radio or television receiver away from the receiver/control.
- Move the antenna leads away from any wire runs to the receiver/control.
- Plug the receiver/control into a different outlet so that it and the radio or television receiver are on different branch circuits.

If necessary, the user should consult the dealer or an experienced radio/television technician for additional suggestions. The user or installer may find the following booklet prepared by the Federal Communications Commission helpful:

"Interference Handbook"

This booklet is available from the U.S. Government Printing Office, Washington, DC 20402.

*The user shall not make any changes or modifications to the equipment unless authorized by the Installation Instructions or User's Manual. Unauthorized changes or modifications could void the user's authority to operate the equipment.*

### **FEDERAL COMMUNICATIONS COMMISSION (FCC) Part 68 STATEMENT**

This equipment complies with Part 68 of the FCC rules. On the front cover of this equipment is a label that contains, among other information, the FCC registration number and ringer equivalence number (REN) for this equipment. If requested, this information must be provided to the telephone company.

This equipment uses the following jacks: An RJ31X is used to connect this equipment to the telephone network.

The REN is used to determine the quantity of devices which may be connected to the telephone line. Excessive RENs on the telephone line may result in the devices not ringing in response to an incoming call. In most, but not all areas, the sum of the RENs should not exceed five (5.0). To be certain of the number of devices that may be connected to the line, as determined by the total RENs, contact the telephone company to determine the maximum REN for the calling area.

If this equipment causes harm to the telephone network, the telephone company will notify you in advance that temporary discontinuance of service may be required. If advance notice is not practical, the telephone company will notify the customer as soon as possible. Also, you will be advised of your right to file a complaint with the FCC if you believe necessary.

The telephone company may make changes in its facilities, equipment, operations, or procedures that could affect the operation of the equipment. If this happens, the telephone company will provide advance notice in order for you to make the necessary modifications in order to maintain uninterrupted service.

If trouble is experienced with this equipment, please contact the manufacturer for repair and warranty information. If the trouble is causing harm to the telephone network, the telephone company may request you remove the equipment from the network until the problem is resolved.

There are no user serviceable components in this product, and all necessary repairs must be made by the manufacturer. Other repair methods may invalidate the FCC registration on this product.

This equipment cannot be used on telephone company-provided coin service. Connection to Party Line Service is subject to state tariffs.

This equipment is hearing-aid compatible.

When programming or making test calls to an emergency number, briefly explain to the dispatcher the reason for the call. Perform such activities in the off-peak hours; such as early morning or late evening.

## CANADIAN DEPARTMENT OF COMMUNICATIONS (DOC) STATEMENT

### NOTICE

The Canadian Department of Communications label identifies certified equipment. This certification means that the equipment meets certain telecommunications network protective, operational and safety requirements. The Department does not guarantee the equipment will operate to the user's satisfaction.

Before installing this equipment, users should ensure that it is permissible to be connected to the facilities of the local telecommunications company. The equipment must also be installed using an acceptable method of connection. In some cases, the company's inside wiring associated with a single line individual service may be extended by means of certified connector assembly (telephone extension cord). The customer should be aware that compliance with the above conditions may not prevent degradation of service in some situations.

Repairs to certified equipment should be made by an authorized Canadian maintenance facility designated by the supplier. Any repairs or alterations made by the user to this equipment, or equipment malfunctions, may give the telecommunications company cause to request the user to disconnect the equipment.

Users should ensure for their own protection that the electrical ground connections of the power utility, telephone lines and internal metallic water pipe system, if present, are connected together. This precaution may be particularly important in rural areas.

**Caution:** User should not attempt to make such connections themselves, but should contact the appropriate electric inspection authority, or electrician, as appropriate.

**The Load Number (LN)** assigned to each terminal device denotes the percentage of the total load to be connected to a telephone loop which is used by the device, to prevent overloading. The termination on a loop may consist of any combination of devices subject only to the requirement that the total of the Load Numbers of all the devices does not exceed 100.

### AVIS

L'étiquette du ministère des Communications du Canada identifie le matériel homologué. Cette étiquette certifie que le matériel est conforme à certaines normes de protection, d'exploitation et de sécurité des réseaux de télécommunications. Le ministère n'assure toutefois pas que le matériel fonctionnera à la satisfaction de l'utilisateur.

Avant d'installer ce matériel, l'utilisateur doit s'assurer qu'il est permis de le raccorder aux installations de l'entreprise locale de télécommunications. Le matériel doit également être installé en suivant une méthode acceptée de raccordement. Dans certains cas, les fils intérieurs de l'entreprise utilisés pour un service individuel à la ligne unique peuvent être prolongés au moyen d'un dispositif homologué de raccordement (cordon prolongateur téléphonique interne). L'abonné ne doit pas oublier qu'il est possible que la conformité aux conditions énoncées ci-dessus n'empêche pas la dégradation du service dans certaines situations. Actuellement, les entreprises de télécommunications ne permettent pas que l'on raccorde leur matériel aux prises d'abonnés, sauf dans les cas précis prévus par les tarifs particuliers de ces entreprises.

Les réparations du matériel homologué doivent être effectuées par un centre d'entretien canadien autorisé désigné par le fournisseur. La compagnie de télécommunications peut demander à l'utilisateur de débrancher un appareil à la suite de réparations ou de modifications effectuées par l'utilisateur ou à cause de mauvais fonctionnement.

Pour sa propre protection, l'utilisateur doit s'assurer que tous les fils de mise en terre de la source d'énergie électrique, des lignes téléphoniques de réseau de conduites d'eau, s'il y en a, soient raccordés ensemble. Cette précaution est particulièrement importante dans les régions rurales.

**Avertissement:** L'utilisateur ne doit pas tenter de faire ces raccordements lui-même; il doit avoir recours à un service d'inspection des installations électriques, ou à un électricien, selon le cas.

**L'indice de charge (IC)** assigné à chaque dispositif terminal pour éviter toute surcharge indique le pourcentage de la charge totale qui peut être raccordé à un circuit téléphonique bouclé utilisé par ce dispositif. La terminaison du circuit bouclé peut être constituée de n'importe quelle combinaison de dispositifs, pourvu que la somme des indices de charge de l'ensemble des dispositifs ne dépasse pas 100.

## **WARNING**

### **THE LIMITATIONS OF THIS ALARM SYSTEM**

While this system is an advanced design security system, it does not offer guaranteed protection against burglary, fire or other emergency. Any alarm system, whether commercial or residential, is subject to compromise or failure to warn for a variety of reasons. For example:

- Intrusion detectors (e.g., passive infrared detectors), smoke detectors, and many other sensing devices will not work without power.

Battery-operated devices will not work without batteries, with dead batteries, or if the batteries are not put in properly. Devices powered solely by AC will not work if their AC power is cut off for any reason, however briefly.

- Signals sent by wireless transmitters may be blocked or reflected by metal before they reach the alarm receiver. Even if the signal path has been recently checked during a weekly test, blockage can occur if a metal object is moved into the path.
- A user may not be able to reach a panic or emergency button quickly enough.
- While smoke detectors have played a key role in reducing residential fire deaths in the United States, they may not activate or provide early warning for a variety of reasons in as many as 35% of all fires, according to data published by the Federal Emergency Management Agency. Some of the reasons smoke detectors used in conjunction with this System may not work are as follows.

Smoke detectors may have been improperly installed and positioned. Smoke detectors may not sense fires that start where smoke cannot reach the detectors, such as chimneys, in walls, or roofs, or on the other side of closed doors. Smoke detectors also may not sense a fire on another level of a residence or building. A second floor detector, for example, may not sense a first floor or basement fire. Finally, smoke detectors have sensing limitations. No smoke detector can sense every kind of fire every time. In general, detectors may not always warn about fires caused by carelessness and safety hazards like smoking in bed, violent explosions, escaping gas, improper storage of flammable materials, overloaded electrical circuits, children playing with matches, or arson. Depending on the nature of the fire and/or location of the smoke detectors, the detector, even if it operates as anticipated, may not provide sufficient warning to allow all occupants to escape in time to prevent injury or death.

- Passive Infrared Motion Detectors can only detect intrusion within the designed ranges as diagrammed in their installation manual. Passive Infrared Detectors do not provide volumetric area protection. They do create multiple beams of protection, and intrusion can only be detected in unobstructed areas covered by those beams. They cannot detect motion or intrusion that takes place behind walls, ceilings, floors, closed doors, glass partitions, glass doors, or windows. Mechanical tampering, masking, painting or spraying of any material on the mirrors, windows or any part of the optical system can reduce their detection ability. Passive Infrared Detectors sense changes in temperature; however, as the ambient temperature of the protected area approaches the temperature range or 90° to 105°F (32° to 40°C), the detection performance can decrease.
- Alarm warning devices such as sirens, bells or horns may not alert people or wake up sleepers if they are located on the other side of closed or partially opened doors. If warning devices are located on a different level of the residence from the bedrooms, they are less likely to waken or alert people inside the bedrooms. Even persons who are awake may not hear the warning if the alarm is muffled by noise from a stereo, radio, air conditioner or other appliance, or by passing traffic. Finally, alarm warning devices, however loud, may not warn hearing-impaired people.
- Telephone lines needed to transmit alarm signals from a premises to a central monitoring station may be out of service or temporarily out of service. Telephone lines are also subject to compromise by sophisticated intruders.
- Even if the system responds to the emergency as intended, however, occupants may have insufficient time to protect themselves from the emergency situation. In the case of a monitored alarm system, authorities may not respond appropriately.
- This equipment, like other electrical devices, is subject to component failure. Even though this equipment is designed to last as long as 20 years, the electronic components could fail at any time.

The most common cause of an alarm system not functioning when an intrusion or fire occurs is inadequate maintenance. This alarm system should be tested weekly to make sure all sensors and transmitters are working properly. The security console (and remote keypad) should be tested as well.

Wireless transmitters (used in some systems) are designed to provide a long battery life under normal operating conditions. Longevity of batteries may be as much as 4 to 7 years, depending on the environment, usage, and the specific wireless device being used. External factors such as humidity, high or low temperatures, as well as large swings in temperature, may all reduce the actual battery life in a given situation. This wireless system, however, can identify a true low battery situation, thus allowing time to arrange a change of battery to maintain protection for that given point within the system.

Installing an alarm system may make the owner eligible for a lower insurance rate, but an alarm system is not a substitute for insurance. Homeowners, property owners and renters should continue to act prudently in protecting themselves and continue to insure their lives and property.



### **ADEMCO LIMITED WARRANTY**

Alarm Device Manufacturing Company, a Division of Pittway Corporation, and its divisions, subsidiaries and affiliates ("Seller"), 165 Eileen Way, Syosset, New York 11791, warrants its products to be in conformance with its own plans and specifications and to be free from defects in materials and workmanship under normal use and service for 18 months from the date stamp control on the product or, for products not having an Ademco date stamp, for 12 months from date of original purchase unless the installation instructions or catalog sets forth a shorter period, in which case the shorter period shall apply. Seller's obligation shall be limited to repairing or replacing, at its option, free of charge for materials or labor, any product which is proved not in compliance with Seller's specifications or proves defective in materials or workmanship under normal use and service. Seller shall have no obligation under this Limited Warranty or otherwise if the product is altered or improperly repaired or serviced by anyone other than Ademco factory service. For warranty service, return product transportation prepaid, to Ademco Factory Service, 165 Eileen Way, Syosset, New York 11791.

THERE ARE NO WARRANTIES, EXPRESS OR IMPLIED, OF MERCHANTABILITY, OR FITNESS FOR A PARTICULAR PURPOSE OR OTHERWISE, WHICH EXTEND BEYOND THE DESCRIPTION ON THE FACE HEREOF. IN NO CASE SHALL SELLER BE LIABLE TO ANYONE FOR ANY CONSEQUENTIAL OR INCIDENTAL DAMAGES FOR BREACH OF THIS OR ANY OTHER WARRANTY, EXPRESS OR IMPLIED, OR UPON ANY OTHER BASIS OF LIABILITY WHATSOEVER, EVEN IF THE LOSS OR DAMAGE IS CAUSED BY THE SELLER'S OWN NEGLIGENCE OR FAULT.

Seller does not represent that the products it sells may not be compromised or circumvented; that the products will prevent any personal injury or property loss by burglary, robbery, fire or otherwise; or that the products will in all cases provide adequate warning or protection. Customer understands that a properly installed and maintained alarm may only reduce the risk of a burglary, robbery, fire or other events occurring without providing an alarm, but it is not insurance or a guarantee that such will not occur or that there will be no personal injury or property loss as a result. CONSEQUENTLY, SELLER SHALL HAVE NO LIABILITY FOR ANY PERSONAL INJURY, PROPERTY DAMAGE OR OTHER LOSS BASED ON A CLAIM THE PRODUCT FAILED TO GIVE WARNING. HOWEVER, IF SELLER IS HELD LIABLE, WHETHER DIRECTLY OR INDIRECTLY, FOR ANY LOSS OR DAMAGE ARISING UNDER THIS LIMITED WARRANTY OR OTHERWISE, REGARDLESS OF CAUSE OR ORIGIN, SELLER'S MAXIMUM LIABILITY SHALL NOT IN ANY CASE EXCEED THE PURCHASE PRICE OF THE PRODUCT, WHICH SHALL BE THE COMPLETE AND EXCLUSIVE REMEDY AGAINST SELLER. This warranty replaces any previous warranties and is the only warranty made by Seller on this product. No increase or alteration, written or verbal, of the obligations of this Limited Warranty is authorized.



N6616 5/93

**ALARM DEVICE MANUFACTURING CO.**  
A DIVISION OF PITTMAN CORP.  
165 EILEEN WAY, SYOSSET, NY 11791

COPYRIGHT © 1993 PITTMAN CORPORATION